

Exotom Exotom-M



Manual No.: 13817001

Date of Release 12.08.1998

Instruction Manual



Exotom / Exotom-M
Instruction Manual

Table of Contents	Page
User's Guide	1
Reference Guide.....	11

Always state *Serial No* and *Voltage/frequency* if you have technical questions or when ordering spare parts. You will find the Serial No. and Voltage on the type plate of the machine itself. We may also need the *Date* and *Article No* of the manual. This information is found on the front cover.

The following restrictions should be observed, as violation of the restrictions may cause cancellation of Struers legal obligations:

Instruction Manuals: Struers Instruction Manual may only be used in connection with Struers equipment covered by the Instruction Manual.

Service Manuals: Struers Service Manual may only be used by a trained technician authorised by Struers. The Service Manual may only be used in connection with Struers equipment covered by the Service Manual.

Struers assumes no responsibility for errors in the manual text/illustrations. The information in this manual is subject to changes without notice. The manual may mention accessories or parts not included in the present version of the equipment.

The contents of this manual is the property of Struers. Reproduction of any part of this manual without the written permission of Struers is not allowed.

All rights reserved. © Struers 1998.

Struers A/S
Valhøjs Allé 176
DK-2610 Rødovre/Copenhagen
Denmark
Telephone +45 36 70 35 00
Fax +45 38 27 27 01



Exotom/Exotom-M

Safety Precaution Sheet

To be read carefully before use

1. The operator(s) should be fully instructed in the use of the machine and its cut-off wheels according to the Instruction Manual and the instructions on the cut-off wheels.
2. The machine must be placed on a safe and stable support. All safety functions and screws of the machine must be in working order.
3. Use only intact cut-off wheels. The cut-off wheels must be approved for min. 3400 rpm/63 m/s.
4. Observe the current safety regulations for handling, mixing, filling, emptying and disposal of the additive for cooling fluid.
5. Do not touch anything inside the cutting chamber while positioning the cut-off wheel with the button RAPID ADVANCE.
6. The sample must be securely clamped in the quick-clamping device or the like. Large or sharp samples must be handled in a safe way.
7. Protruding work pieces should be shielded or marked.
8. Do not put your hands through the rubber curtain during operation of the machine.
9. Do not open the protection screen before the cut-off wheel has stopped.
10. Struers recommends the use of exhaustion as the cutting materials may emit harmful gasses or dust. See the instructions of the cut-off wheel.

The equipment is designed for use with consumables supplied by Struers. If subjected to misuse, improper installation, alteration, neglect, accident or improper repair, Struers will accept no responsibility for damage(s) to the user or the equipment.

Dismantling of any part of the equipment, during service or repair, should always be performed by a qualified technician (electromechanical, electronic, mechanical, pneumatic, etc.).

User's Guide

Table of Contents	Page
1. Getting Started	
Checking the Contents of Packing.....	3
Exotom	3
Exotom-M.....	3
Recirculation Cooling Unit.....	3
Unpacking Exotom/Exotom-M.....	4
Placing Exotom/Exotom-M.....	4
Getting Acquainted with Exotom/Exotom-M.....	4
Details of Exotom	5
Details of Exotom-M.....	5
Noise Level.....	6
Supplying Power	6
Direction of the Cut-off Wheel	6
Supplying Compressed Air.....	6
Connecting the Recirculation Unit	6
2. Operation	
Using the Controls.....	7
Front Panels of Exotom.....	7
Front Panel of Exotom-M.....	7
Front Panel Controls	8
Changing the Cut-off Wheel.....	9
Clamping the Sample	9
Positioning the Cut-off Wheel.....	9
Cutting on Exotom.....	9
Starting the Cutting.....	9
Stopping the Cutting.....	9
Cutting on Exotom-M.....	10
Starting the Cutting.....	10
Stopping the Cutting.....	10
Excicut.....	10
Flushing the Cutting Chamber.....	10
Refilling of Cooling Water	10

Exotom / Exotom-M
Instruction Manual

1. Getting Started

Checking the Contents of Packing

In the packing box you should find the following parts:

Exotom

- 1 Exotom
- 3 Cut-off wheels (81EXO, 83EXO and 86EXO)
- 6 Cardboard flanges for cut-off wheels 81EXO, 83EXO and 86EXO
- 1 Fork spanner (32 mm) for mounting of cut-off wheel
- 1 Additive (1 l) for cooling water
- 1 Socket spanner (19 mm)
- 1 Hose for compressed air (3000 mm)
- 2 Hose Clamps (12 mm)
- 1 Hose connection
- 1 Grease gun
- 1 Hexagon spanner, 3 mm, for the quick clamping device
- 1 Angled socket spanner, 13 mm, for the quick clamping device
- 1 Crossbeam
- 1 Hexagon spanner, 10 mm, for mounting crossbeam
- 2 Screws for mounting crossbeam
- 1 Set of Instruction Manuals

Exotom-M

- 1 Exotom-M
- 3 Cut-off wheels (81EXO, 83EXO and 86EXO)
- 6 Cardboard flanges for above
- 1 Fork spanner (32 mm) for mounting of cut-off wheel
- 1 Additive (1 l) for cooling water
- 1 Socket spanner (19 mm)
- 1 Grease gun
- 1 Hexagon spanner, 3 mm, for the quick clamping device
- 1 Angled socket spanner, 13 mm, for the quick clamping device
- 1 Crossbeam
- 1 Hexagon spanner, 10 mm, for mounting crossbeam
- 2 Screws for mounting crossbeam
- 1 Set of Instruction Manuals

Recirculation Cooling Unit

- 1 Recirculation cooling unit
- 1 Lid for cooling unit
- 1 Sieve for cooling water
- 2 Plastic inserts for the tank
- 1 Trolley for cooling unit

Unpacking Exotom/Exotom-M

- Remove the door from the cupboard and take out the loose parts (trolley, tank etc.).
- Place the pumps in the cutting chamber.
- Unscrew the nuts from the four bolts fixing the machine to the pallet.

Placing Exotom/Exotom-M

- Fasten the enclosed crossbeam at the bottom part of the door posts.
- Lift of the machine from the pallet by means of a fork-lift truck from the front side, or with a crane, and place it in a suitable location.
- Unscrew the front crossbeam.
- Adjust the machine shoes so that the machine stands firmly. Then mount the door.

Getting Acquainted with Exotom/Exotom-M

Take a moment to familiarise yourself with the location and names of the Exotom/Exotom-M components.

Exotom	Exotom-M
① Front panel controls	① Front panel controls
② Main switch	② Main switch
③ Cutting chamber	③ Cutting chamber
④ Protection guard	④ Protection guard
⑤ Guard for cut-off wheel	⑤ Guard for cut-off wheel
⑥ Cut-off wheel	⑥ Cut-off wheel
⑦ Finger grip for guard	⑦ Finger grip for guard
⑧ Spindle lock button	⑧ Spindle lock button
⑨ Cutting table	⑨ Cutting table
⑩ Quick-clamping device	⑩ Quick-clamping device
⑪ Flushing hose	⑪ Flushing hose
	⑫ Cutting handle

Details of Exotom

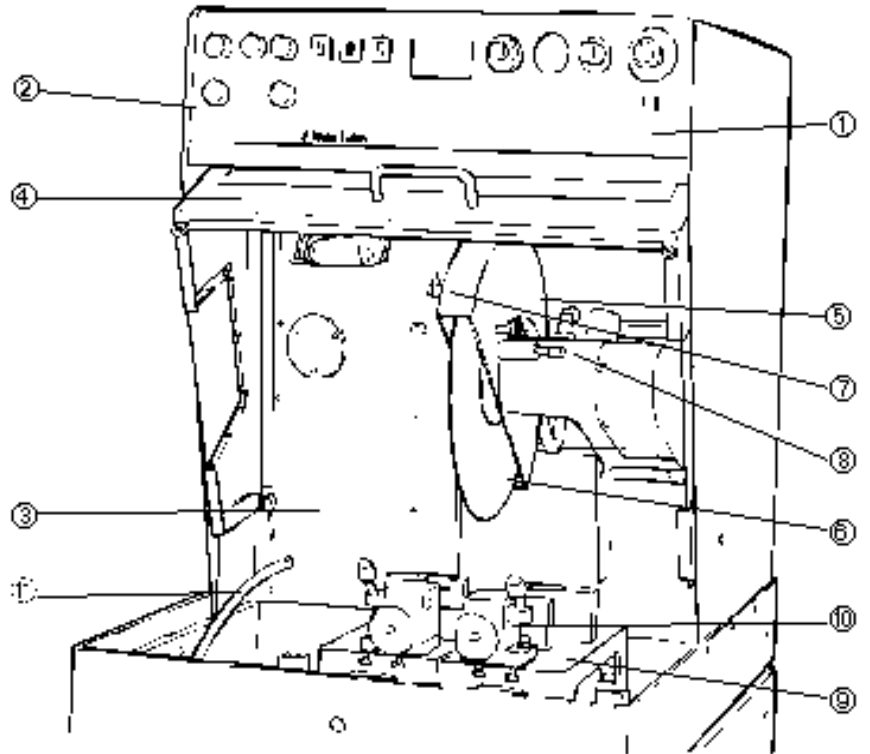

Details of Exotom-M

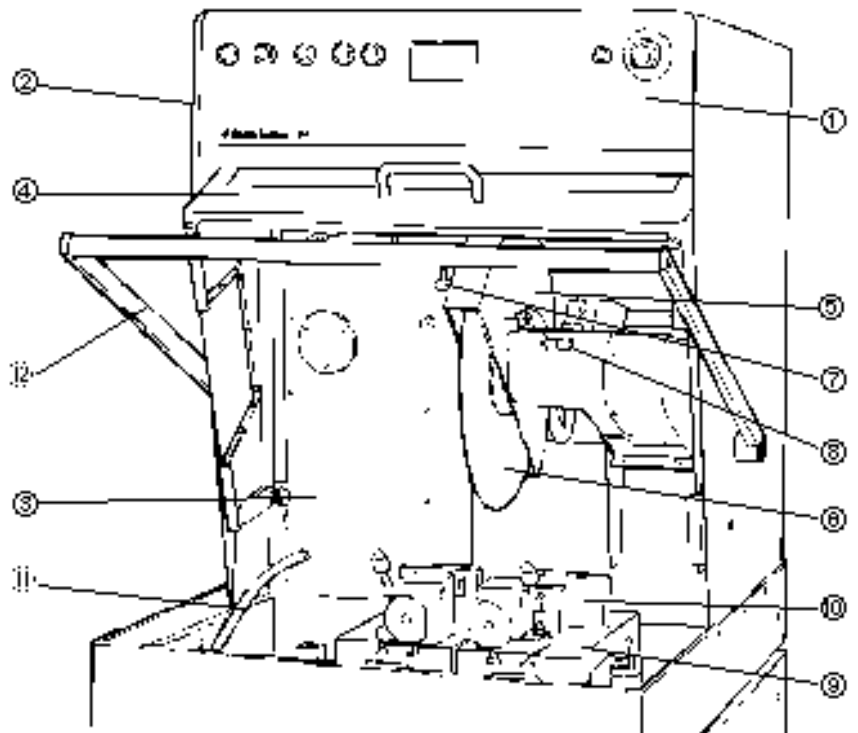

Noise Level

Approx. 85 dB (A) measured at idle running, at a distance of 1.0 m/39.4" from the machine.

Supplying Power

IMPORTANT
Check that the mains voltage corresponds to the voltage stated on the type plate on the side of the machine.

Exotom/Exotom-M is factory mounted with electric cable. Mount a plug on the cable.

Black and Brown: phase
Yellow/green: earth

Direction of the Cut-off Wheel

Check that the cut-off wheel rotates in the direction indicated on the label attached to the inner guard of Exotom/Exotom-M. If the direction of rotation is incorrect, switch two of the phases.

Supplying Compressed Air
(Exotom Model only)

- Press the hose connection of the hose for compressed air into the inlet of Exotom placed on the left side of the machine. Fasten it with a hose clamp (12 mm).
- Connect the other end of the hose to the compressed air source by means of a hose clamp (12 mm).

Connecting the Recirculation Unit
(Both Exotom and Exotom-M)

- Place a disposable plastic insert (EXOSP) in the tank and fold it over the edge. The pre-punched holes should be in front of the overflow aperture in the tank.
- Place the cooling unit on the trolley and fill it up with 65 l of water i.e. 8-10 cm from the upper edge. Add additive in the quantity which is stated on the bottle label and stir a little.
- Put the lid on the tank and place the sieve and the pumps in the lid.
- Connect the two inlet hoses to the pumps.
- Place the tank in the cupboard and adjust the outlet hoses so that they discharge into the sieve.

2. Operation

Using the Controls

Front Panel of Exotom

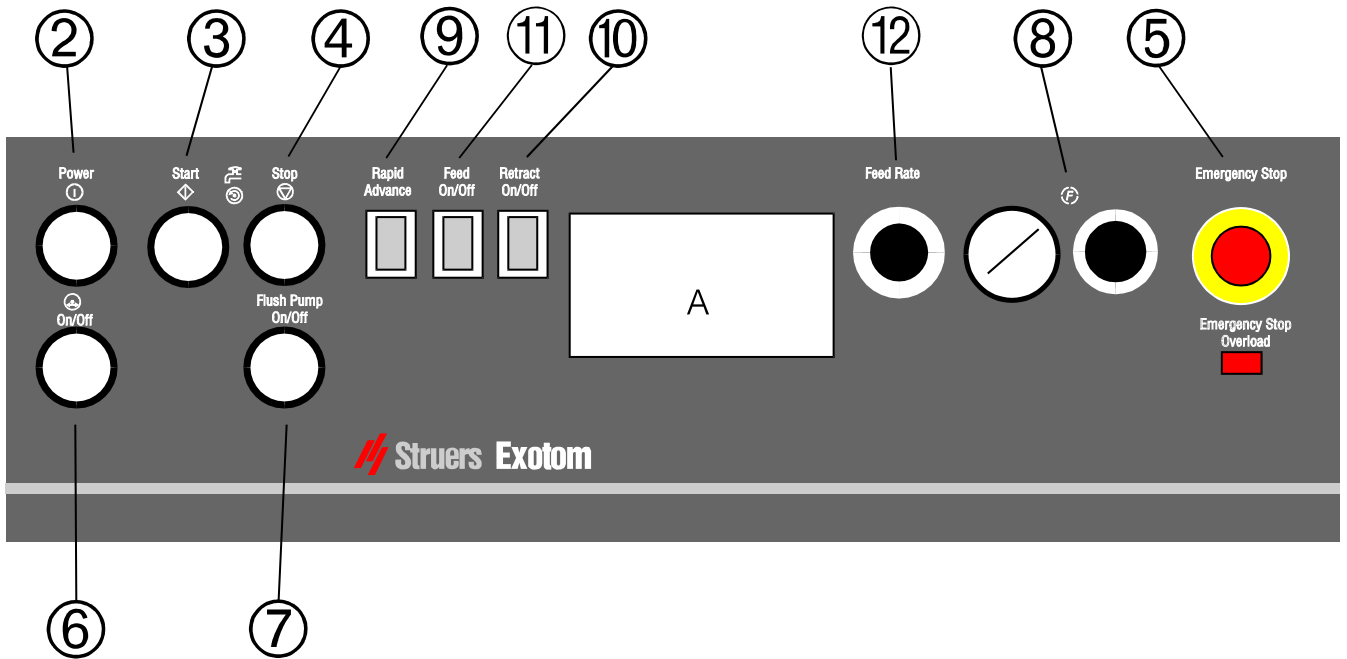

Front Panel of Exotom-M

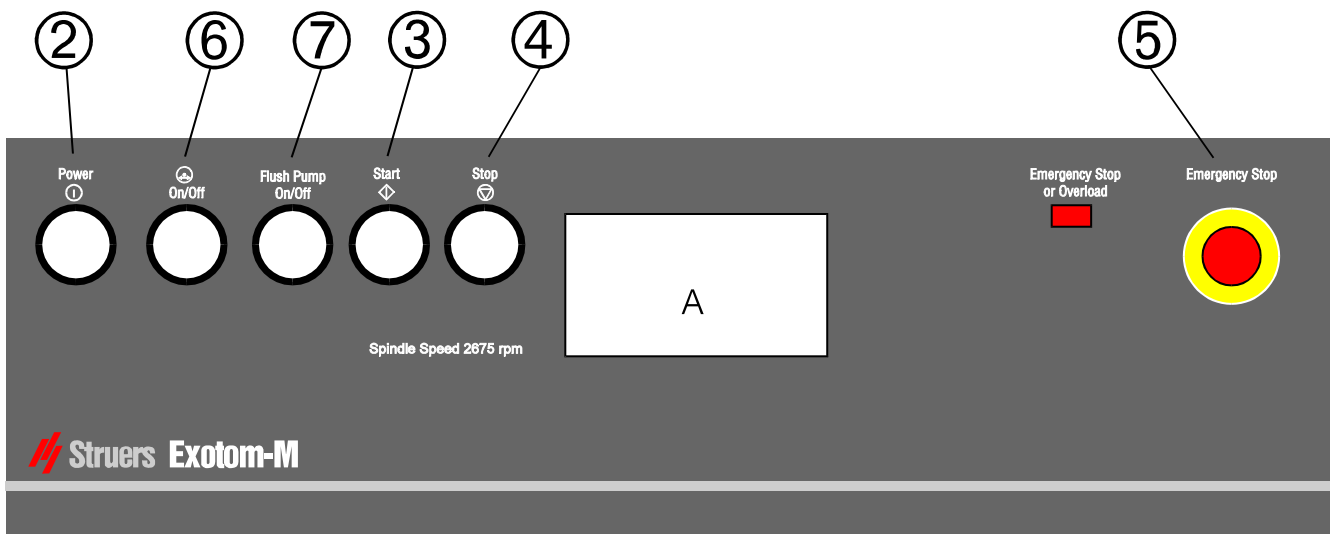

Front Panel Controls

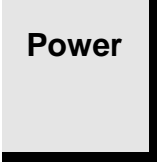
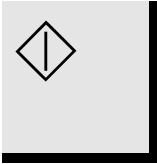
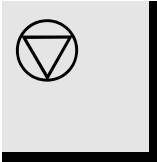
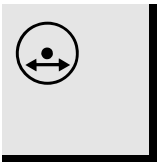
Name	Key	Function	Name	Key	Function
Exotom and Exotom-M					
① MAIN SWITCH		Turns on the main power of the machine. The main switch is located on the left side of the machine.	⑧ FORCE		Adjusting knob for setting the force.
② POWER		Turns on/off the power of the machine. A switch for daily use. The button lights when activated.	⑨ RAPID ADVANCE		Moves the cut-off wheel down towards the sample for as long as the button is pressed. The button lights when activated.
③ START		Starts the machine, recirculation unit, and Excicut when in ON-position. The button lights green when the safety screen is closed and the button can be pressed.	⑩ RETRACT		When pressed shortly the cut-off wheel will return to its top position. At quick repress the return movement will stop. The button lights when activated.
④ STOP		Stops the machine, recirculation unit, and Excicut when in ON-position. The button lights red when it can be activated.	⑪ FEED		Moves the cut-off wheel down. The button lights when activated.
⑤ EMERGENCY STOP		Interrupts all functions. A red light indicates that the button has been activated or overload of the motors. Pull the button to release the light.	⑫ FEED RATE		Adjusting knob for setting the feed speed. The knob is provided with a locking pin. When it is pressed down it prevents a set speed rate from being unintentionally changed.
⑥ EXCICUT		Starts/stops the Excicut motion of the cut-off wheel. The button lights when activated.			
⑦ FLUSH PUMP		Starts/stops the water flush. The button lights when activated.			

Changing the Cut-off Wheel

- Turn the finger grip to the left and swing the guard for the cut-off wheel open.
- Turn the cut-off wheel and press the button situated to the right so that it catches the flange and locks the spindle.
- Remove the nut by means of a fork spanner (32 mm).
- Remove the flange and the cut-off wheel.

IMPORTANT

Exotom/Exotom-M is left-hand threaded.

- Mount the new cut-off wheel with a cardboard washer on each side.
- Mount the flange and nut. Tighten carefully and close the guard.

Clamping the Sample

- Place the sample between the clamp and the back stop.
- Push the clamp towards the sample, and lock the quick clamping device with the locking handle.

Positioning the Cut-off Wheel

After clamping you may lower the cut-off wheel into position, min. 1 mm above the sample, to test the correct position of the cut on the sample:

- Press the button RAPID ADVANCE, to lower the cut-off wheel. The cut-off wheel stops when the button is released.
- Leave the cut-off wheel in position before you press the button START ◊.

Cutting on Exotom

Starting the Cutting

- Position the cut-off wheel.
- Close the protection guard.
- Press the button START ◊. The cut-off wheel starts rotating and the cooling water starts running.
- Press the button FEED ON/OFF and the cut-off wheel will slowly move down into the sample.

Stopping the Cutting

- Exotom automatically stops cutting when the sample is cut through. The cut-off wheel moves to its top position, stops rotating and the recirculation unit is turned off.
- The machine can always be stopped by pressing the button RETRACT ON/OFF.
- The machine can be stopped at any time during operation by pressing the button STOP ⊙.

Cutting on Exotom-M

Starting the Cutting

- Close the protection guard.
- Press the button START . The cut-off wheel starts rotating and the cooling water starts running.
- Lower the cut-off wheel onto the sample by pulling the cutting handle slowly until it comes into contact with the sample. Do not apply much cutting pressure.
- Let the cut-off wheel work itself a little into the sample. Then increase the pressure and begin cutting. Keep the pressure constant.
- When the cut-off wheel is almost through the sample the cutting pressure should be reduced.

Stopping the Cutting

- After cutting, return the cut-off wheel to top position. Stop the cut-off wheel and the cooling water by pressing STOP .

Excicut

- To start and stop the Excicut feature, press the button EXCICUT ON/OFF .

Flushing the Cutting Chamber

To ensure a longer lifetime of your Exotom, Struers strongly recommends cleaning of the cutting chamber with the flushing hose every day:

- Point the flushing hose towards the button of the cutting chamber.
- Press the button FLUSH PUMP ON/OFF to turn the water on. Adjust the flow by means of the lever on the spray nozzle.
- Clean the cutting chamber thoroughly.
- Turn off the water by pressing the button FLUSH PUMP ON/OFF again.

Refilling of Cooling Water

- Refill cooling water in the tank by pouring the water through the sieve until the water level is 2-3 cm from the upper edge.

NB! Never refill by pouring the water in the cutting chamber as it would be impossible to check the increasing level in the tank.

IMPORTANT

Always maintain the correct concentration of Struers Additive in the cooling water (percentage stated on the container of the Additive). Remember to add Struers Additive each time you refill with water.

Reference Guide

Table of Contents	Page
1. Accessories	
Cut-off Wheels.....	12
Accessories	13
2. Maintenance	
Cleaning	14
Recirculation Unit	14
3. Service	
Every Week	15
Every 10th Week.....	15
Every 6th Month.....	15
4. Technical Data	16

1. Accessories

Cut-off Wheels

Application	Dimensions	Grinding agent	300 mm	Code
For direct and oscillating cutting of extremely hard steels (> 60HRC)	350x2.5x32mm	Al ₂ O ₃		81EXO
For direct and oscillating cutting of steels (<60HRC). Extremely hard (white cast iron) or ductile (18/8 or St60) steel types are cut with oscillating cutting. Gives good wheel economy	350x2.5x32mm	Al ₂ O ₃		83EXO
For cutting with Excicut. Universal cut off-wheel for steel-alloys less than 60 HRC and for general use.	350x2.5x32mm	Al ₂ O ₃		8UEXO
Primarily for oscillating cutting of steels (<60HRC). Gives very good wheel economy	350x2.5x32mm	Al ₂ O ₃		84EXO
For direct and oscillating cutting in non-ferrous metals. Primarily for oscillating cutting	350x2.5x32mm	SiC		86EXO
For direct cutting of titanium and its alloys, as well as other non-ferrous metals	350x2.5x32mm	SiC	56UNI	90EXO
For direct cutting of sintered carbides and ceramics	305x1.8x32mm 350x1.8x32mm	Diamond Diamond	25EXO	26EXO

Accessories

Specification	Code
<i>Extra Clamping Table</i> additional table for support of very large work pieces.	UNFIT / EXOBA
<i>Quick Clamping Device</i>	UNIEL / UNIQI
<i>Clamping Tools</i> for Exotom.	UNIOF / EXOOF
<i>Fume Extractor Kit</i> for Exotom (connecting tube ø50 mm).	EXOKI
<i>Movable Cutting Table</i> for long cuts. To move the specimen parallel to the cut-off wheel, thereby increasing the cutting length up to 150 mm.	EXOLA
<i>Movable Cutting Table</i> for parallel cuts. Positions the specimen at right angle to the cut-off wheel. With dial (setting 0.1 mm) movable up to 100 mm.	EXOEL
<i>Disposable plastic inserts</i> for the recirculation unit tank, 10 pcs.	EXOSP

2. Maintenance

Cleaning

Wash the slot between disc screen and cutting arm clean every day.

The sieve must be emptied each day after a thorough washing down of the cutting chamber and, especially, the clamping table with the T-slots.

The flushing pump must be removed and the sieve cleaned at least once a week, or as necessary, depending on use.

Recirculation Unit

The cooling unit should be checked for cooling water every week and refilled when the flushing pump cannot reach the cooling water. Remember to use Struers Additive (pH should be around 9). Replace if pH is α 8.0. To check the concentration of Additive use a refractometer (0-10 Brix, see diagram.). Concentration = 2 x Brix.

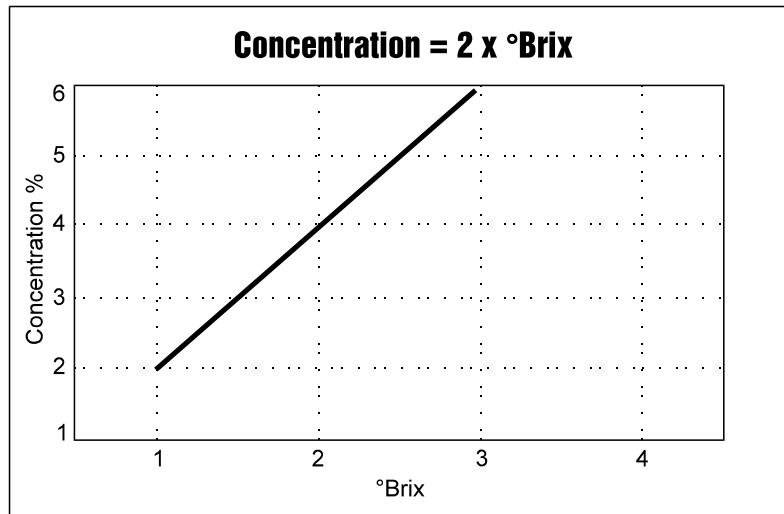

3. Service

Every Week

- Grease the nut for cut-off wheel spindle. Use water resistant grease.
- Spindle tightening. Remove the fixed flange and wash off any dirt behind the flange.

Every 10th Week

- Grease the eccentric bearing. Use the grease from the grease gun supplied with the apparatus. You gain access to the grease nipple by dismounting the round cover plate in the right side of Exotom. On Exotom-M, the grease should be applied through the centre of the fixing piece of the lever.

IMPORTANT

When the machine is in continuous function for 8 hours or more, grease the eccentric bearing every day.

- Grease hinges and lock for cut-off wheel screen.

Every 6th Month

- Belt tightening. Remove rear plate, release the motor; now tighten the belt using the bolt closest to the belt pulley. Remember to adjust the position of the motor so that it is at right angles to the belts before the motor is fixed again.
- Check the oil level. While the rear plate is removed the oil level can be checked on the reservoir tubes. Each mark corresponds to an extreme position of the cutting arm. R1 should be at the upper marking and R2 at the lower marking when the cut-off wheel is in its upper position. *When filling up and changing the oil, please use Shell Tellus 32.*
- Grease the power transmission part. While the rear plate is dismantled the guide block is greased.
- Use Shell Albida Grease LX for greasing the eccentric shaft and the quick clamping device as well as the power transmission part. If the cut-off wheel spindle is serviced, the gasket ring should be greased with special water resistant grease, e.g. Staburags NBU 12.

4. Technical Data

Subject		Specifications	
		Metric/ International	US
Compressed air supply	Pressure: 6-9.9 bar Consumption: approx. 4 l/min		
Cutting motor		5.5 kW	7.5 HP
Cooling pump Capacity	Approx. 80 l/min (50 Hz) Approx. 96 l/min (60 Hz)		
Flushing pump Capacity	Approx. 50 l/min (50 Hz) Approx. 60 l/min (60 Hz)		
Cooling tank Volume	65 l		
Cut-off wheel		350 mm x 32 mm x 2.5 mm	13.8" x 1.25" x 0.1"
Cutting speed	50 m/s at 2675 rpm		
Max. diameter of work piece		110 mm	4.3"
	Max. length of cut, for a work piece Max. thickness of cut, for a work piece	250 mm approx. 40 mm	1.6"
Max. dimensions of work piece	Thickness Width Length (longer sections of bar and rod can be accommodated)	140 mm 475 mm 600 mm	5.5" 18.7" 23.6"
Cutting Tables	Cutting table Extra table	300 x 300 mm 150 x 300 mm	(12" x 12") (6" x 12")
Noise Level	Approx.85 dB (A) measured at idle running, at a distance of 1.0 m/39.4" from the machine.		
Voltage/ frequency/ Max. current consumption	3 x 200 V/50-60 Hz 3 x 220 V/50-60 Hz 3 x 380 V/50 Hz 3 x 415 V/50 Hz 3 x 440 V/60 Hz 3 x 480 V/60 Hz 3 x 500 V/50 Hz	24.8 A 23.5 A 13.8 A 13.8 A 13.6 A 13.6 A 11.0 A	
Dimensions and Weight	Width	660 mm	26"
	Depth	900 mm	35.4"
	Height	1650 mm	65"
	Weight	390 kg	

Exotom Exotom-M



Manual No.: 13817001

Date of Release: 12.08 1998
Revised: 01.06.2002

Spare Parts and Diagrams



Exotom / Exotom-M
Spare Parts and Diagrams

**Always state *Serial No* and *Voltage/frequency*
if you have technical questions or when ordering spare parts.**

The following restrictions should be observed, as violation of the restrictions may cause cancellation of Struers legal obligations:

Instruction Manuals: Struers Instruction Manual may only be used in connection with Struers equipment covered by the Instruction Manual.

Service Manuals: Struers Service Manual may only be used by a trained technician authorised by Struers. The Service Manual may only be used in connection with Struers equipment covered by the Service Manual.

Struers assumes no responsibility for errors in the manual text/illustrations. The information in this manual is subject to changes without notice. The manual may mention accessories or parts not included in the present version of the equipment.

The contents of this manual is the property of Struers. Reproduction of any part of this manual without the written permission of Struers is not allowed.

All rights reserved. © Struers 2002.

Struers A/S
Valhøjs Allé 176
DK-2610 Rødovre/Copenhagen
Denmark
Telephone +45 36 70 35 00
Telefax: +45 38 27 27 01

1. Spare parts and Diagrams

Table of contents

Photos and drawings

Fig	Title
1	Exotom, complete
2	Exotom-M, complete
3	Exotom, front
4	Exotom-M, front
5	Fastening the cutting wheel
6	Cleaning the cutting table
8	Exhaust
9	Motor, details
10	Front, details
11	Lights, details
12a/b	V-belt, belt guard
13	Protection screen
14	Mounting strip, horizontal
15	Mounting strip, oblique
16	Flange and spindle
17	Cutting wheel guard
18	Oil reservoir and valves
19	Belt pulley
20	Pulley for gear motor
21	Cutting table
22	Cooling tank and trolley
23	Hose branch
24	Hose branch
25	Hexagonal nipple
26	Tube branch
27a/b	Cylinder and shock absorber
28	Mounting plate for electronics and hydropneumatics
29	Water expeller/filter unit
30	Emergency stop, Manometer
31	Throttle valves
32	Main switch and fuses
33	Transformers and relays
34	PCB console
35	Door, locking device
36	Arm
37a/b	Belts
38	V-belt motor, detail
50	Spindle arm
51	Eccentric shaft
51-M	Eccentric shaft, Exotom-M
52	Spindle lock case
53	Quick-clamping house

Exotom / Exotom-M
Spare Parts and Diagrams

List of special parts for Exotom-M

Diagrams

Exotom

Pneumatic diagram	13810147A
Power circuit diagram	13810065A
Wiring diagram	13810266B
Control circuit diagram for auto model	13810272D
Logic control diagram	13810384C
Component illustration logic control board	13810388C

Exotom-M

Wiring diagram, Exotom-M	14100105
Control circuit diagram, Exotom-M	14100111D
Diagram for inductive supply and relay, Exotom-M	14100150B
Component Illustration, Exotom-M	14100155

The drawings are not to scale. Some of the drawings may contain position numbers not used in connection with this manual.

Photos and Drawings

Exotom / Exotom-M
Spare Parts and Diagrams

Pos. and Description

Cat. No.

Fig. 1 Exotom, complete

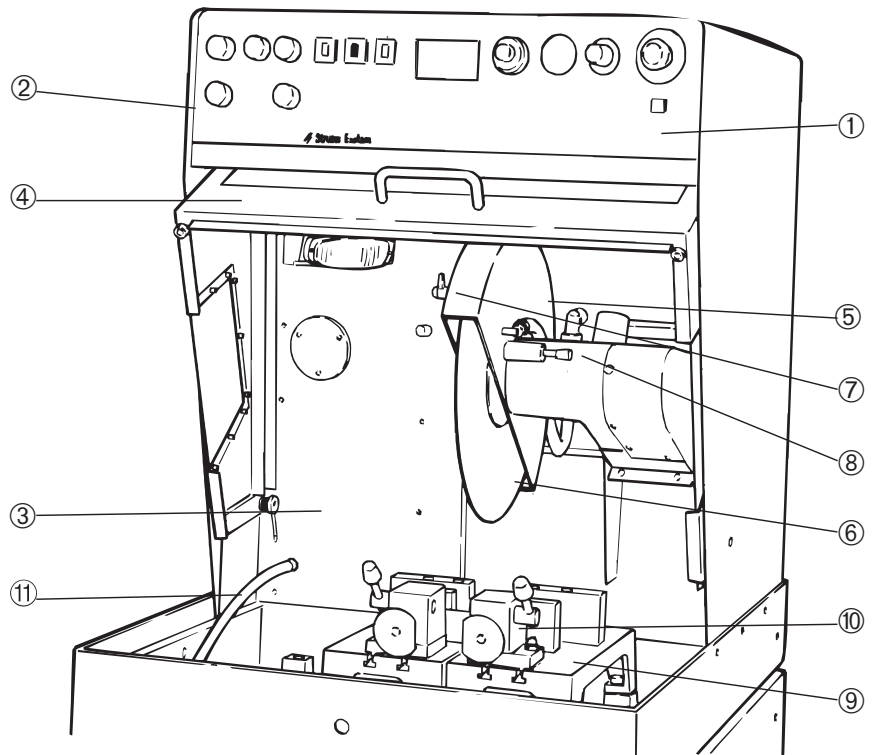
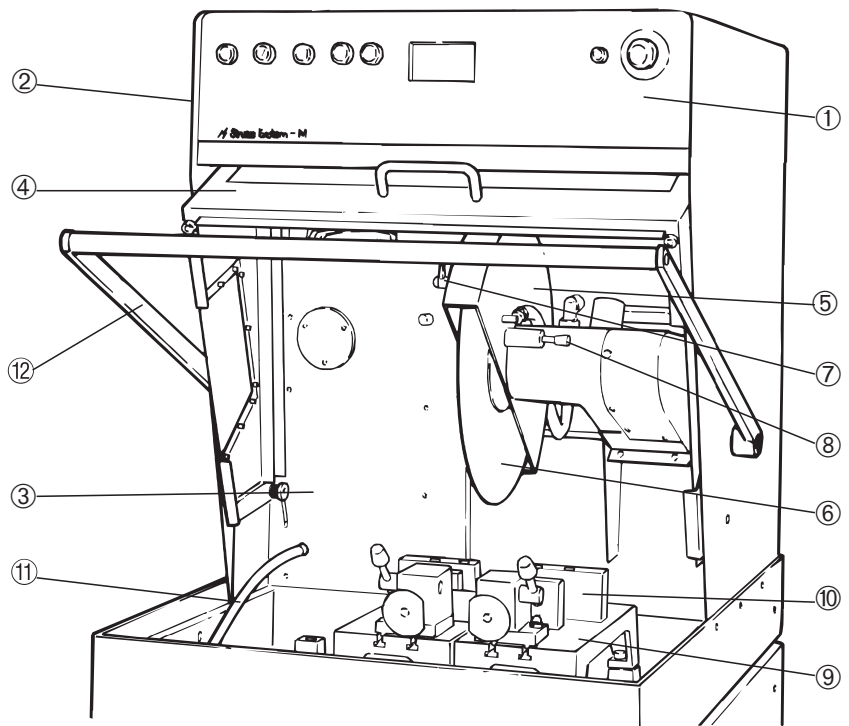

Fig. 2 Exotom-M, complete



Pos. and Description

Cat. No.

Fig. 3 Exotom, Front

Front plate with foil, Exotom-M 1410082

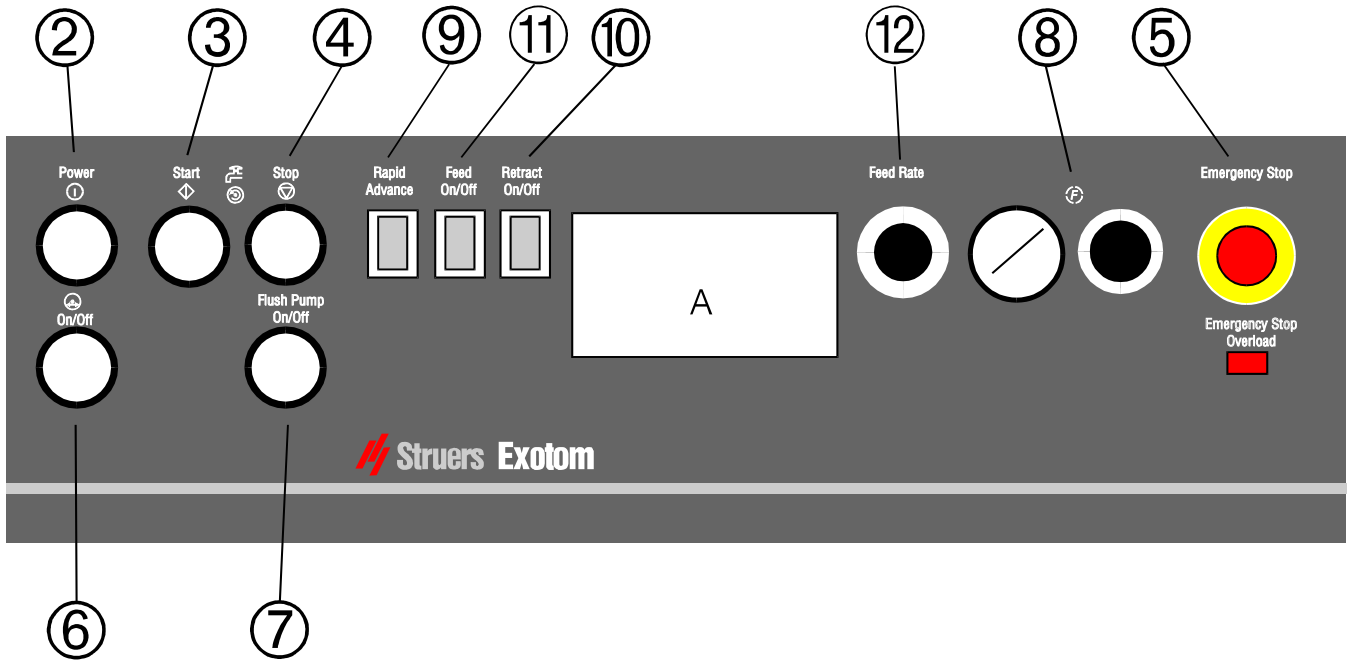
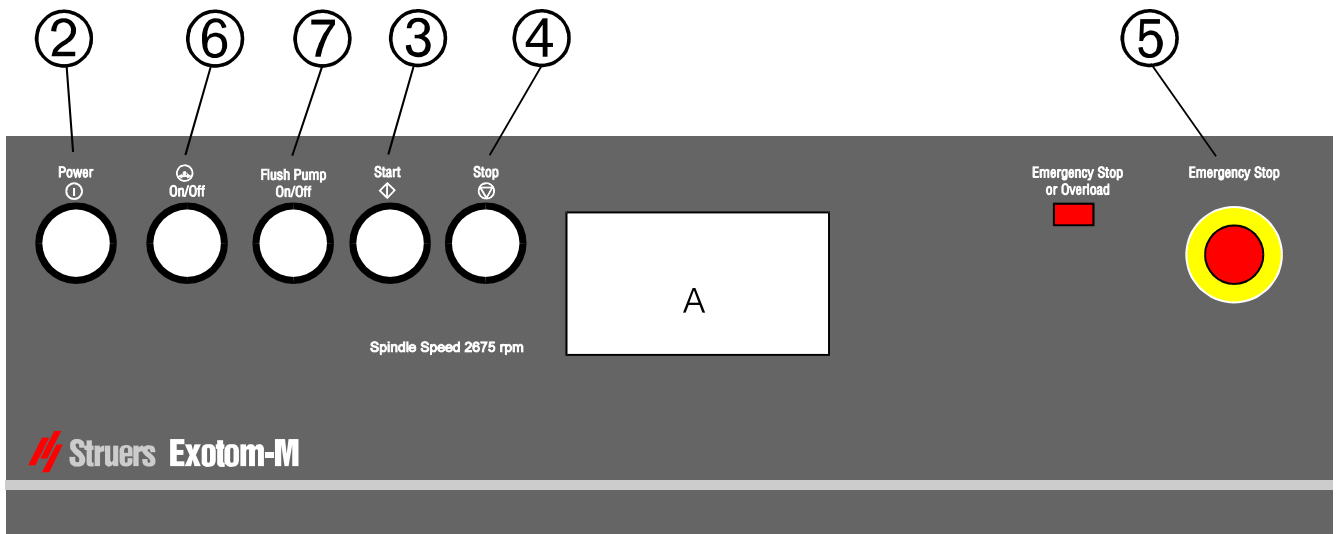

Fig. 4 Exotom-M, Front



Pos. and Description

Cat. No.

- 1 Rubber cover, lower.....13810726

**Fig. 5 Fastening
the Cutting Wheel**



**Fig. 6 Cleaning
the Cutting Table**

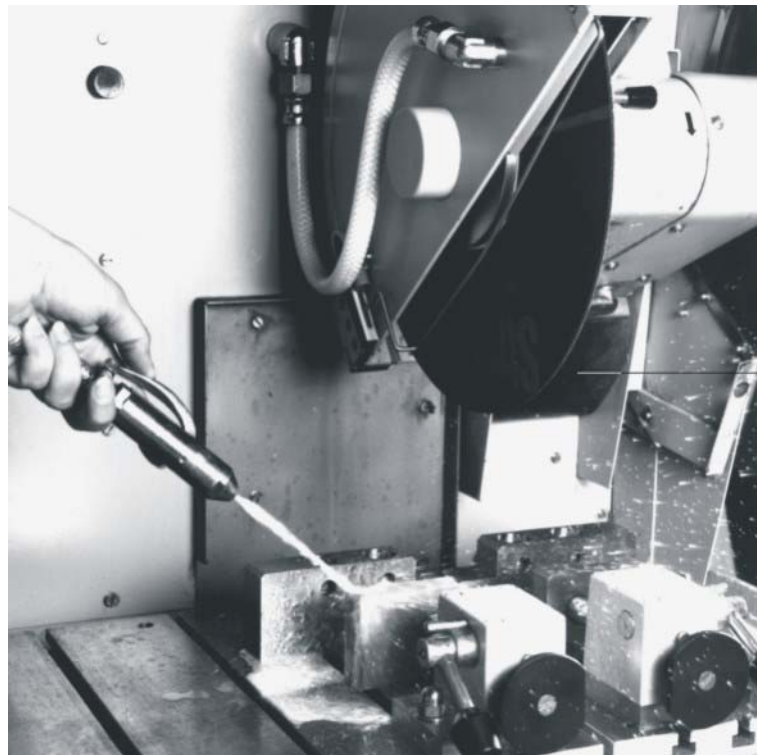

Pos. and Description

Cat. No.

Fig. 8 Exhaust



①

Fig. 25

Fig. 26

Pos. and Description	Cat. No.
1 Top rear plate	13819053
1 Back Plate (Removed = not visible on figure)	13819044
2 Lower Casing	R3819049
3 Mounting Plate (Hidden = not visible on figure)	13819054
3 Top plate	13819045
4 Cover for pointer	13819051
5 Pointer	13819002
6 Dial for pointer	381MP295
7 Stop for protection screen	381MP007
Stop for spindle arm, Exotom-M	14108001
8 Cast bed	13819033
Column (Exotom-M)	14108004
Bumper (Exotom-M)	2GS00315
9 Spring	13810135
10 Thread plate for lower plate (9.2)	13818002
Grease gun	381MP415
Cardboard discs, 25 pcs	381MP431
Angle for pulley	381MP387
11 Pulley	13810129
12 Gas Spring Replacement Kit, see fig. 15	13810115

Fig. 9 Motor, Details

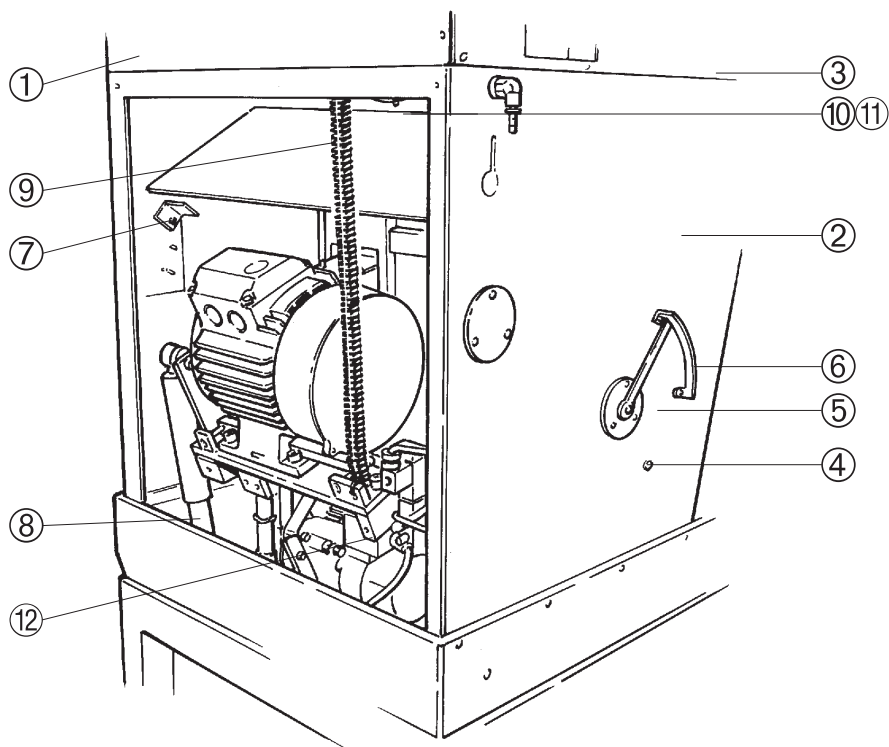

Pos. and Description	Cat. No.
1 Handle.....	2GH20002
2 Front Plate without foil	381MP353
2 Front plate foil.....	13810209
4 Emergency stop push button without switch element S4	381MP439
5 Bourns Dial.....	381MP412
Cable entry	381MP291
Fork wrench.....	2GR00232
Socket spanner for jaw	2GR00313
6 Stop knob for protection screen	13810490
7 Manometer.....	13810238
S1,S5,S6 Push button S1, S5, S6 without switch element.....	381MP249
S2 Push button, S2	381MP250
S3 Push button, S3	381MP251
Push button symbol, set.....	13810230
S1-S6 Push button cap.	2SA30102
S7-S9 Push button S7-S9	2SA40066
S7-S9 Push button cap, S7-S9.....	R3810258
Bulb, S7-S9	2HG10002
Inset (3 pcs.) S7-S9.....	2SA41200
B Sensor B1, Exotom, protective cover closed.....	381MP436A
B Sensor B1, Exotom-M, protective cover closed	381MP336
H4 Lamp H4 (red)	2HK20342

Fig. 10 Front, Details

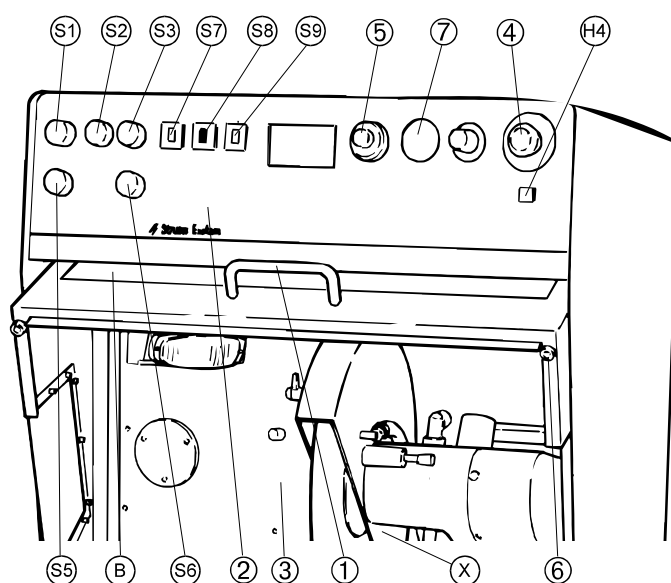

Pos. and Description	Cat. No.
1 Sweep strip	381MP363
2 Intermediate plate.....	13819064
3 Lamp	381MP264
Bulb for 381MP264	381MP265
Glass for 381MP264	2HW00002
4 Lamp angle/plate.....	13819068
Lamp console	13819067
Bumper	2GS00120
7 Baffle.....	381MP426

Fig. 11 Lights, Details

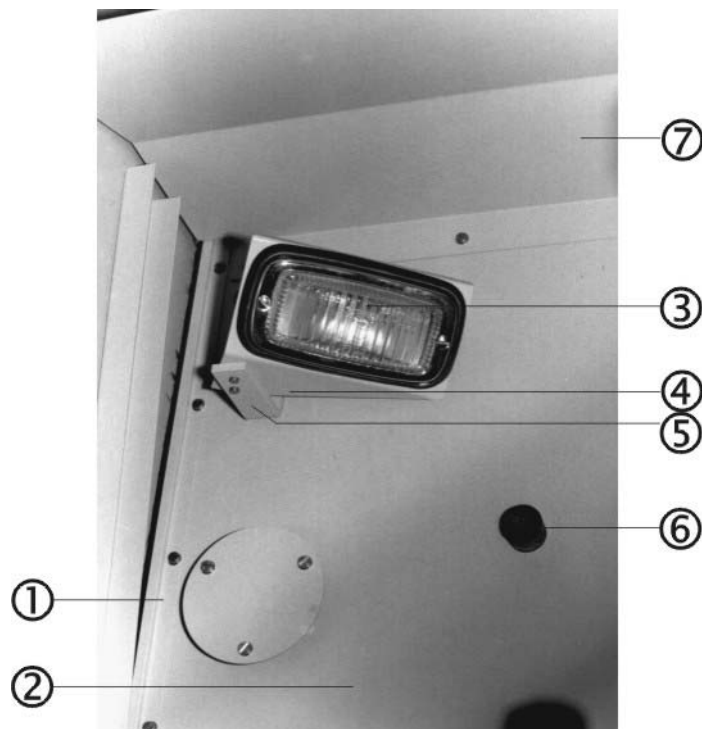

Pos. and Description	Cat. No.
1 Baffle.....	381MP361
2 V-belt guard, front.....	R3819048
3 V-belt guard, upper.....	381MP364
4 V-belt guard, lower.....	381MP365
5 Rubber cover, upper.....	13810725
6 Mounting strip for rubber cover.....	381MP368

Fig. 12a V-belt, Guard

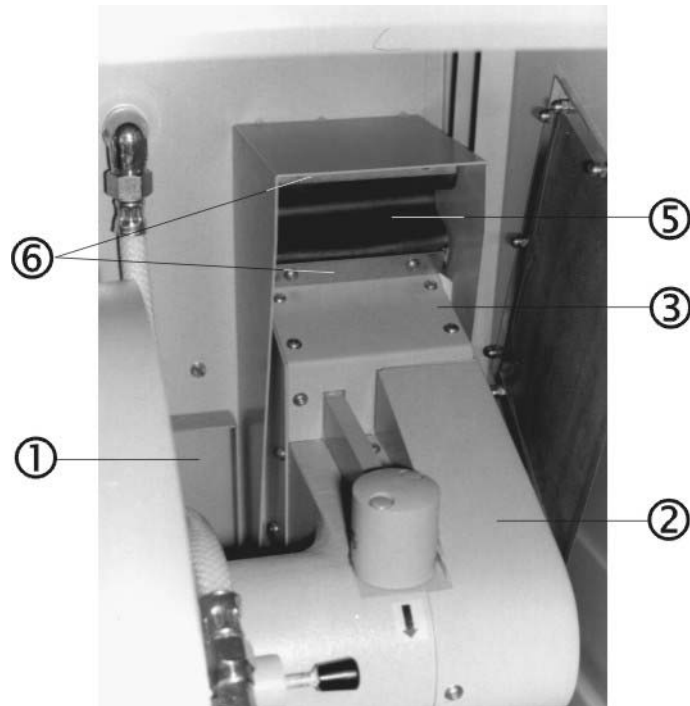
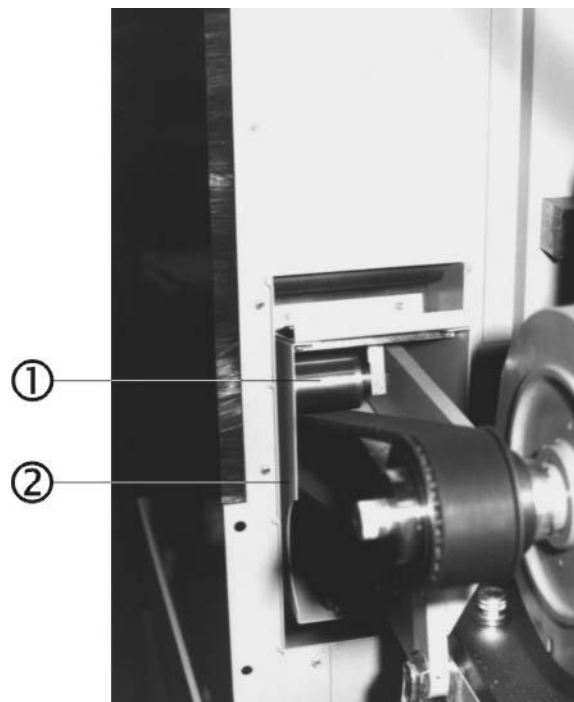

Fig. 12b V-belt, Wheel



Pos. and Description

Cat. No.

1	Protection screen, complete	381MP390
2	Window paction	381MP032
3	Protection rail.....	13818002
5	Rubber plate	381MP036
7	Bolt, with washer	381MP427
6	Slide strip complete.....	13810464
	Sealing band for window, 2 m	2IP00401
	Window strip, horizontal	381MP040
	Window strip, lower vertical.....	381MP041
	Window strip, upper vertical	381MP042

Fig. 13 Protection Screen

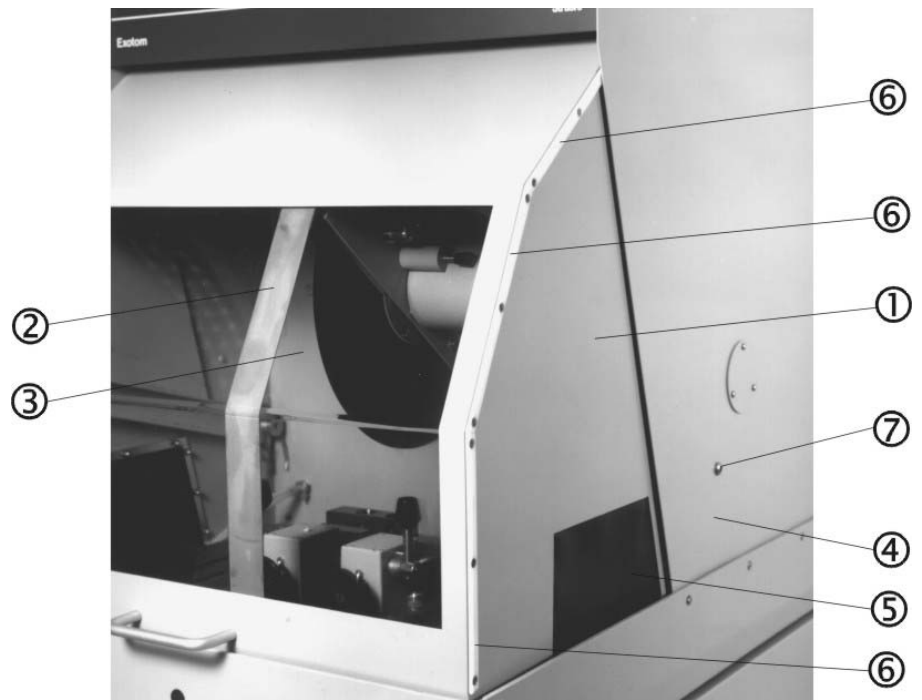

Pos. and Description	Cat. No.
1 Rubber plate	13810515
2 Mounting strip, horizontal.....	381MP370
3 Mounting strip, vertical, right hand side.....	381MP371
4 Mounting strip, vertical, left hand side	381MP369

**Fig. 14 Mounting Strip,
Horizontal**



Pos. and Description	Cat. No.
1 Mounting strip, oblique.....	381MP369
2 Gas Spring 150N Lift-o-Mat 580	2YS00422
3 Bottom holder, left-hand side	13810149
Bottom holder, Right-hand side	13810148
4 Shaft for top holder	13810143
5 Top holder for U-rail	13810139
6 Shaft for bottom holder	13810144

Fig. 15 Mounting Strip, Oblique

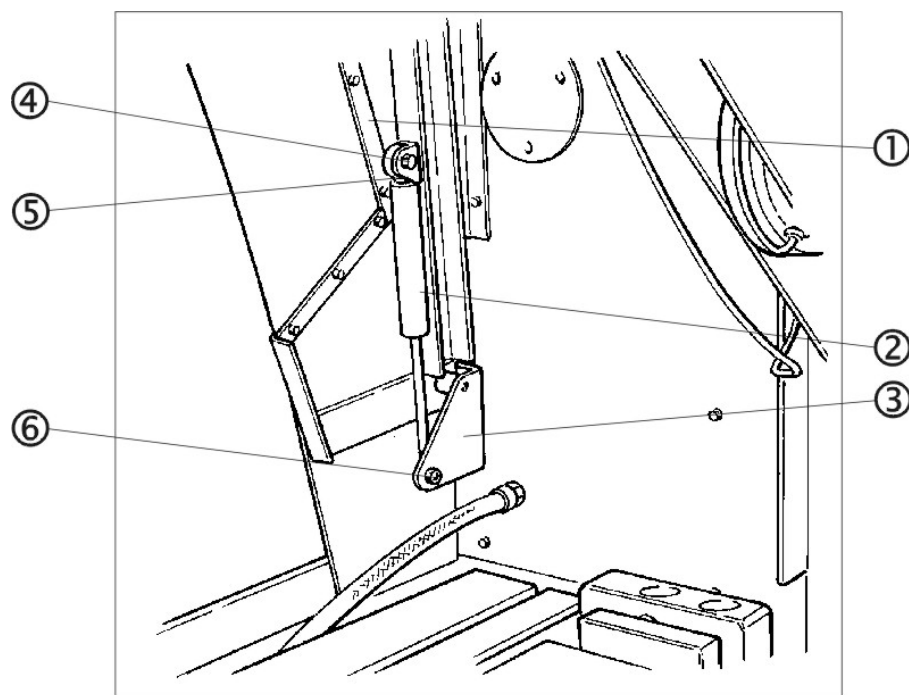

Pos. and Description	Cat. No.
1 Flange, inside	381MP433
2 Flange, outside	381MP043
3 Spindle nut (left-hand tread).....	13810122
4 Cutting wheel guard	381MP394
4 Cutting wheel guard, complete.....	13810403

Fig. 16 Flange and Spindle

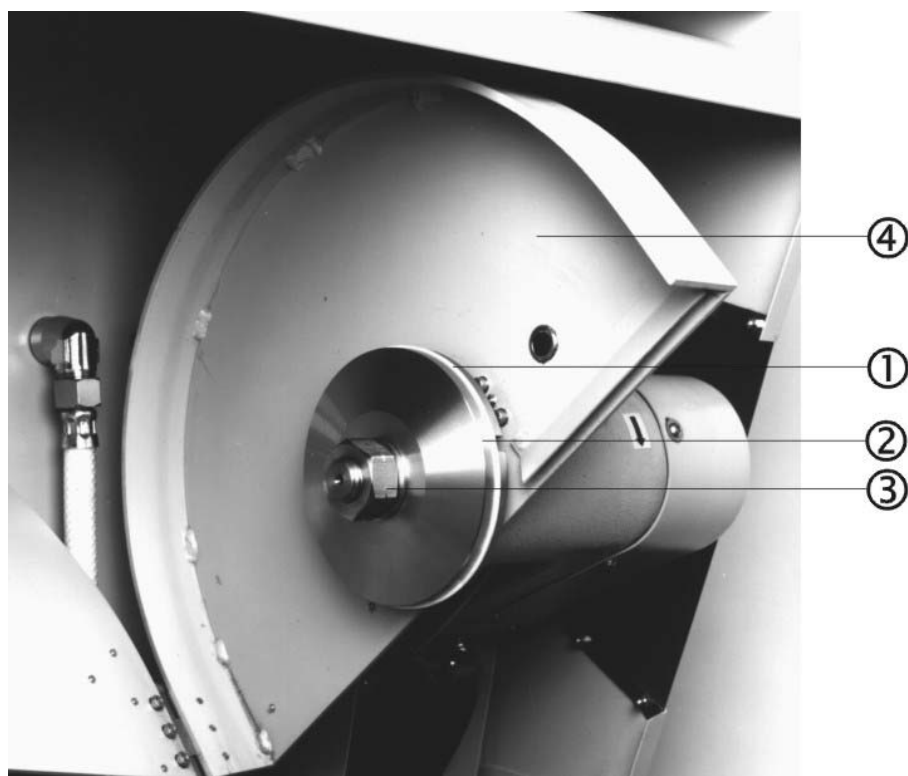

Pos. and Description	Cat. No.
1 Door for cutting wheel guard.....	381MP429
2 Hinge for cutting wheel guard.....	381MP078
3 Sensor strap.....	13810453
4 Door locking device.....	381MP082
5 Guide for strap	381MP420
6 Baffle and spark plate.....	381MP361
B Sensor B2,.....	381MP263

Fig. 17 Cutting Wheel Guard

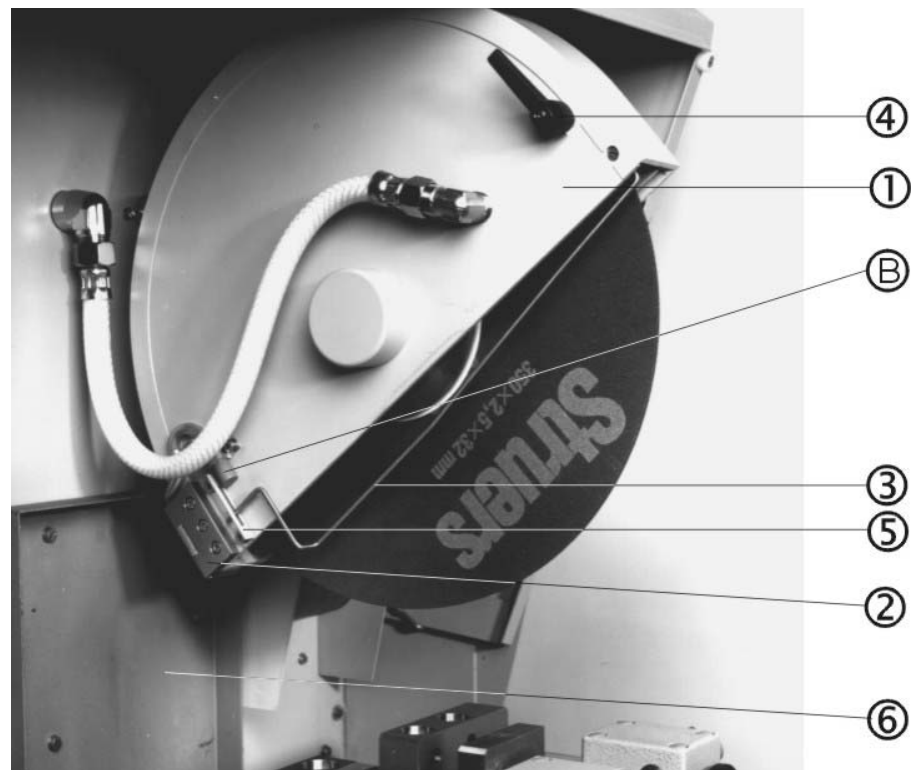

Pos. and Description	Cat. No.
R1+R2 Oil reservoir (R1 + R2)	381MP338
Y1+Y2 Solenoid valve, Y1, Y2, Y5	2YM10001
Y3 Solenoid valve, Y3	2YM10005
Y4 Solenoid valve, Y4	394MP058
1 Silencer for Y3	2YL00010
2 Silencer for Y4	2YL00005
Fitting, CK-1/8-PK-6-KU	2NF20017
Fitting, CK-1/8-PK-4-KU	381MP194
Fitting, CK-1/8-PK-3-KU	2NF20090
Fitting, ACK-1/4-PK-4	2NF10018
Angle fitting GCK-1/4-PK-4-KU	2NF10087
Angle fitting GCK-1/8-PK-6-KU	2NF20054
Angle fitting GCK-1/8-PK-4-KU	381MP199
Distributor FCK-3-PK-6-KU	2NF20104
Double nipple E-1/8-1/8	2NF40011
Oil, 1 l	381MP204

Fig. 18 Oil Reservoir and Valves

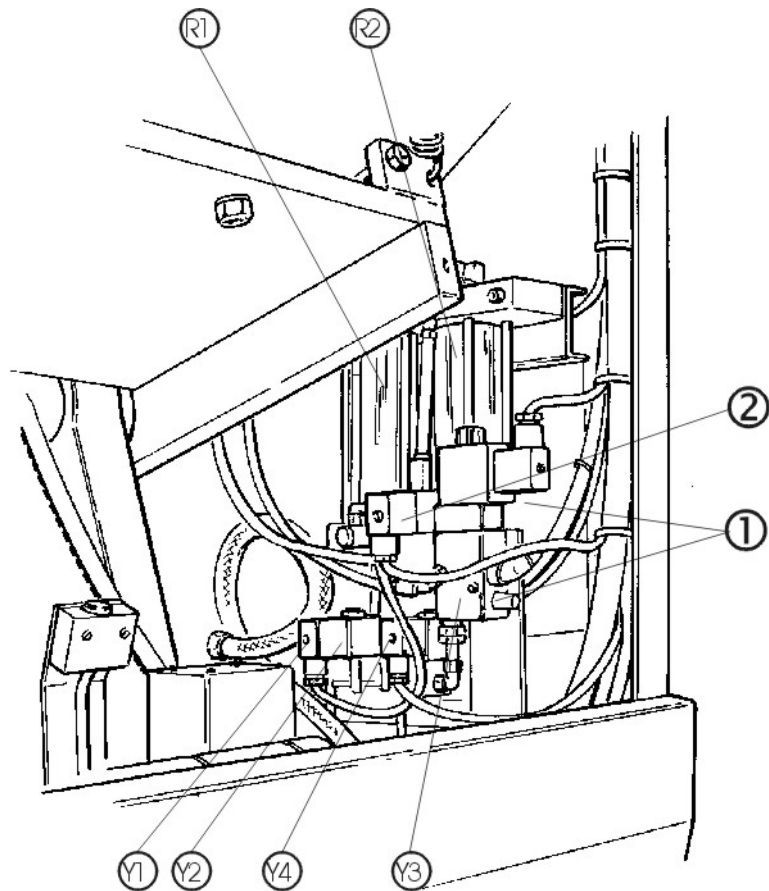

Pos. and Description	Cat. No.
1 Timing belt pulley, spindle	381MP104
2 Timing Belt 322L 100, L=819,15	2JT00025

Fig. 19 Belt Pulley

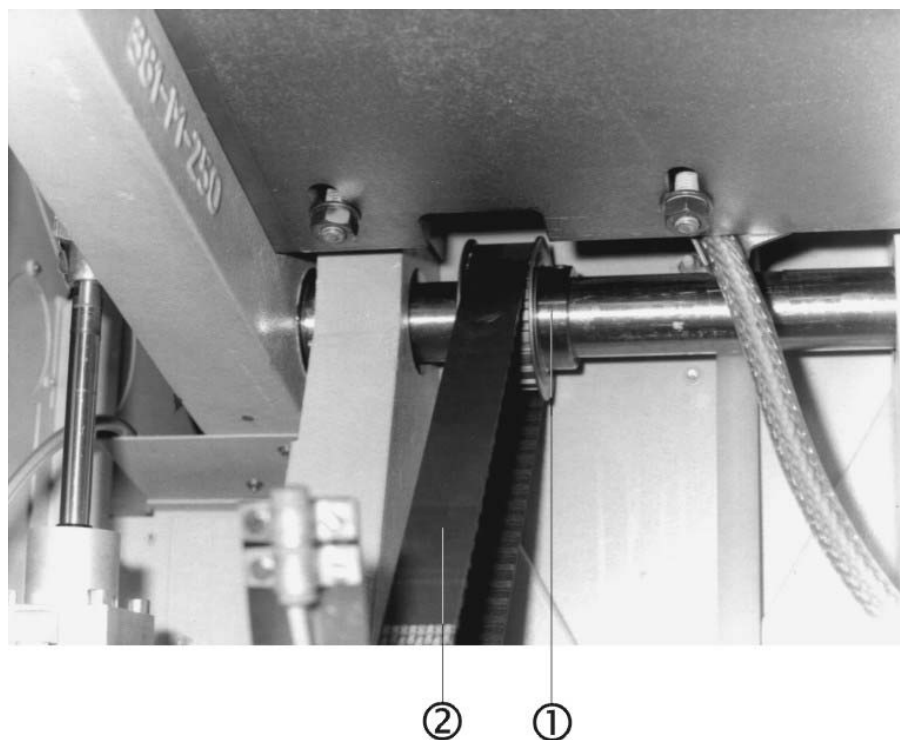

Pos. and Description	Cat. No.
1 Timing belt pulley for gear motor	381MP106
2 Eccentric motor 3x220V/50-60Hz	13810810
2 Eccentric motor 3x380-500V/50-60Hz.....	381MP214
3 Motor bracket	381MP283
4 Console for sensor	381MP296
B Sensor B3, arm position up.....	381MP436B

Fig. 20 Pulley for Gear Motor

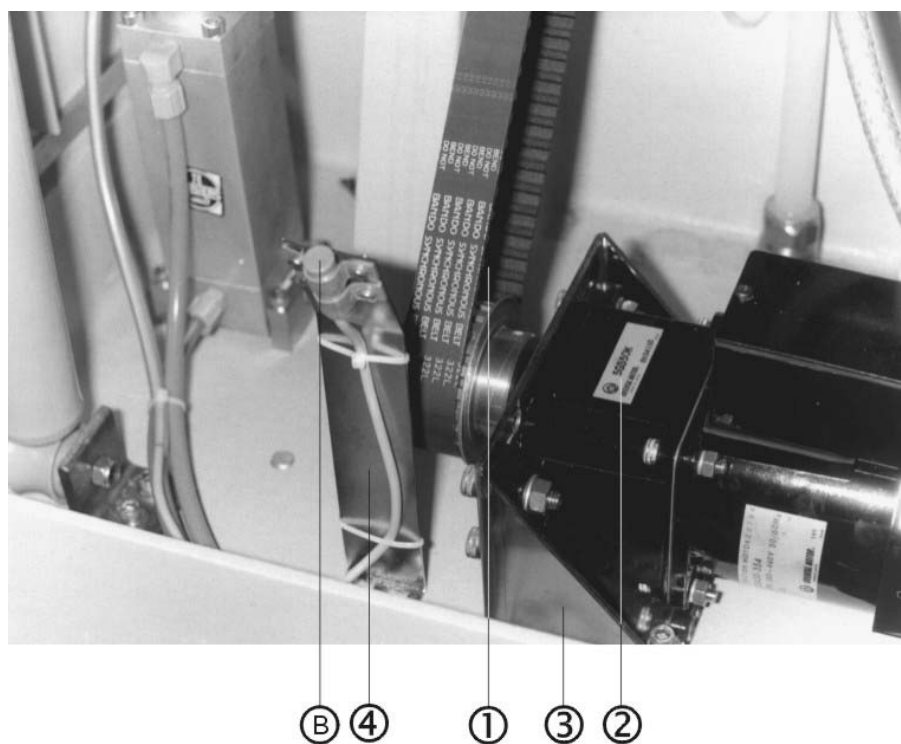

Pos. and Description	Cat. No.
1 UNIFT, Cutting table with 10mm T-slots	03816901
1 UNIBA; Replacement Stainless Steel Bands.....	05336905
2-8 Fixed jaw, with T-screws for 10mm T-slots	R5330310
3-6 UNIRI, Quick-clamping device, complete, right for 10mm T-slots	05336907
7 UNILE, Quick-clamping device, complete, left for 10mm T-slots	05336906

Fig. 21 Cutting Table

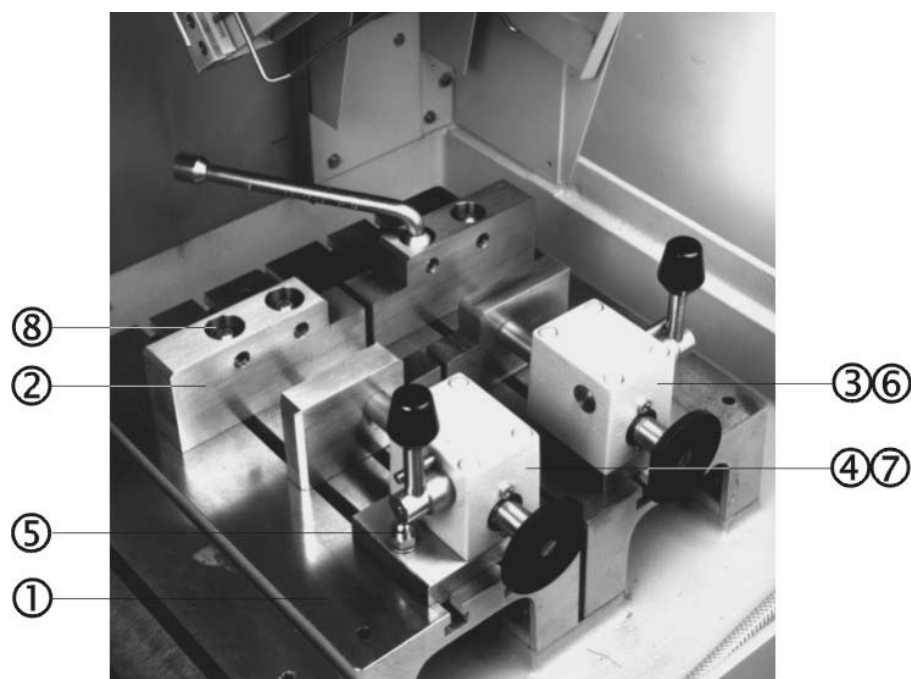

Pos. and Description	Cat. No.
1 Cooling tank	381MP140
Lid for cooling Tank	381MP142
2 Trolley	381MP430
3 Lid	381MP142
4 Sieve for return water.....	14980071
5 Elbow joint for flush pump (1/2").....	381MP144A
6 Elbow joint for cooling pump (3/4")	381MP145A
7 Pump, cooling. (3 x 220 - 240V/ 50 Hz).....	381MP408A
7 Pump, cooling. (3 x 380 - 440V/ 50 Hz).....	381MP408A
7 Pump, cooling. (3 x 200 - 220V/ 60 Hz).....	381MP409A
7 Pump, cooling. (3 x 380 - 480V/ 60 Hz).....	381MP409A
8 Pump, flushing (3 x 200 - 240V/ 50-60Hz)	381MP410A
8 Pump, flushing (3 x 380 - 480V/ 50-60Hz)	381MP410B
Sieve for Pump, 2AB4 (Ø99)	14980074
9 Clamp for sieve.....	2NS20215
10 Holder for sieve	315MP052

Fig. 22 Cooling Tank and Trolley

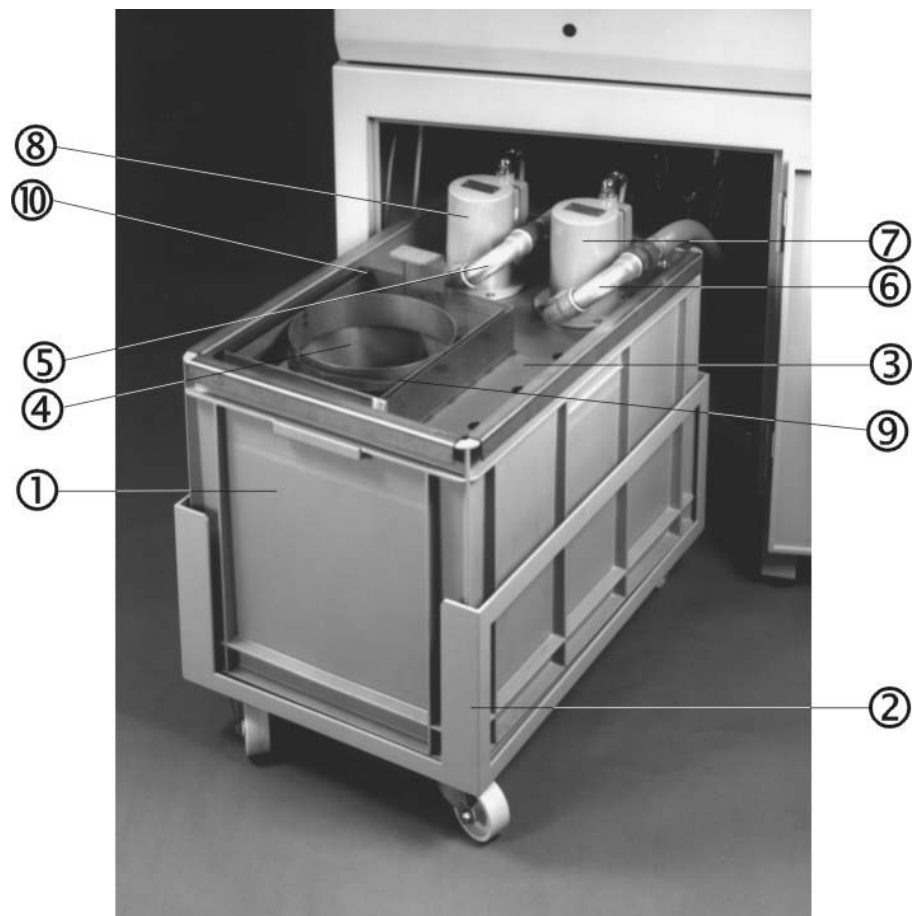

Pos. and Description	Cat. No.
1+2 Hose branch with union nut and gasket.....	2NG20065
3 Hose	2NU20325
4 Hose clamp.....	2NS12409
5 Hose branch.....	2NG20070
6 Elbow	2NG10002
7 Nipple.....	13810682
8 Nut	381MP152
9 Reduction socket.....	381MP153
10 Delivery pipe.....	2NP10014
11 Elbow, 90°	2NG10040
12 Distribute branch	13810680
13 Elbow, 90°	13810684
14 Delivery hose	2NU90020
15 Elbow	2NF40098
16 Nipple.....	381MP333

Fig. 23 Hose Branch

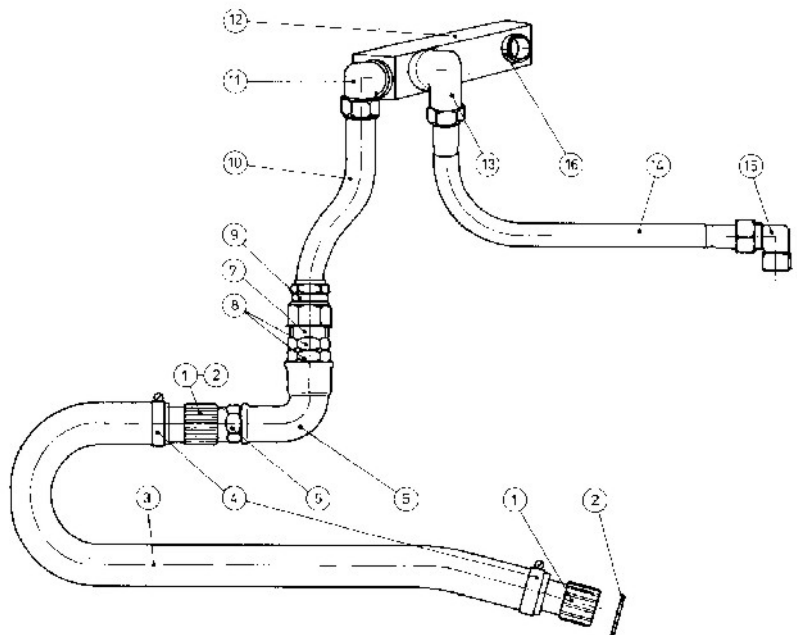

Pos. and Description

Cat. No.

1+2	Hose branch with union nut and gasket.....	2NG20063
3	Hose	2NU20316
4	Hose clamp.....	2NS11309
5	Reducing nipple.....	13810689
6	Hose	2NU90021
7	Hose branch.....	2NF40086
8	Hose clamp.....	2NS11309
9	Hose	2NU29310
10	Water gun	381MP168

Fig. 24 Hose Branch

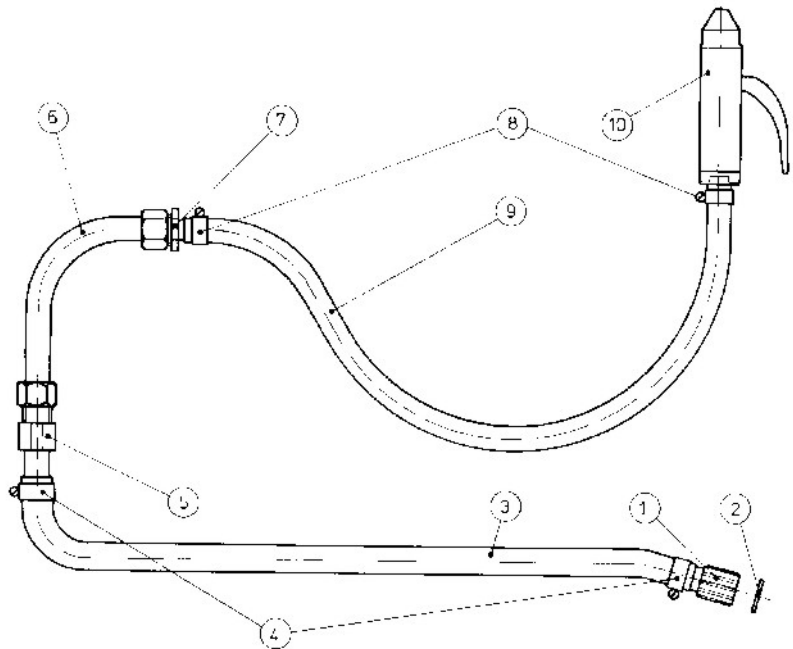

Pos. and Description	Cat. No.
1 Hexagonal nipple.....	13810688
2 Elbow (67,5°) with rubber ring	2NG20567
3 Elbow (15°) with rubber ring	2NG20515
4 Elbow (45°) with rubber ring	2NG20545

Fig. 25 Hexagonal Nipple

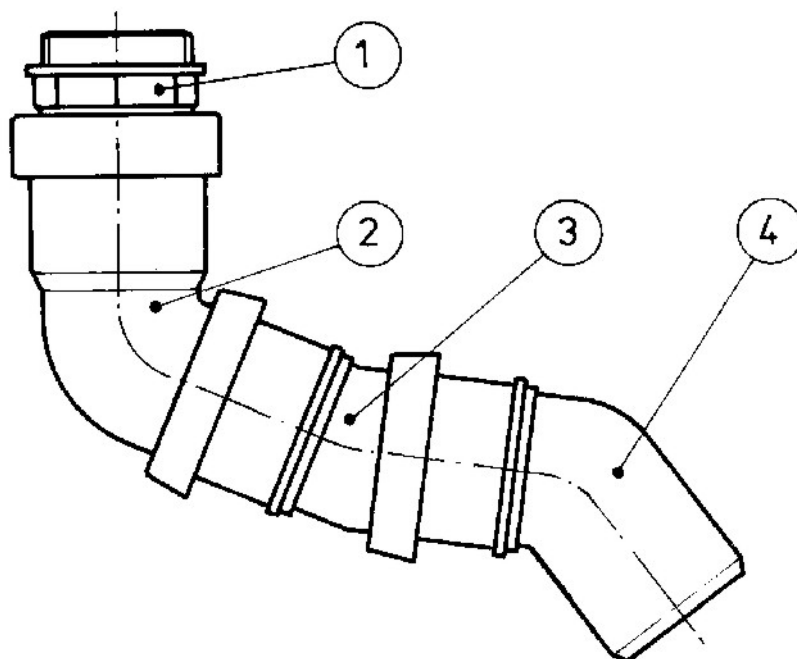

Pos. and Description	Cat. No.
1 Branch.....	381MP418
2 Outlet hose.....	381MP419

Fig. 26 Tube Branch

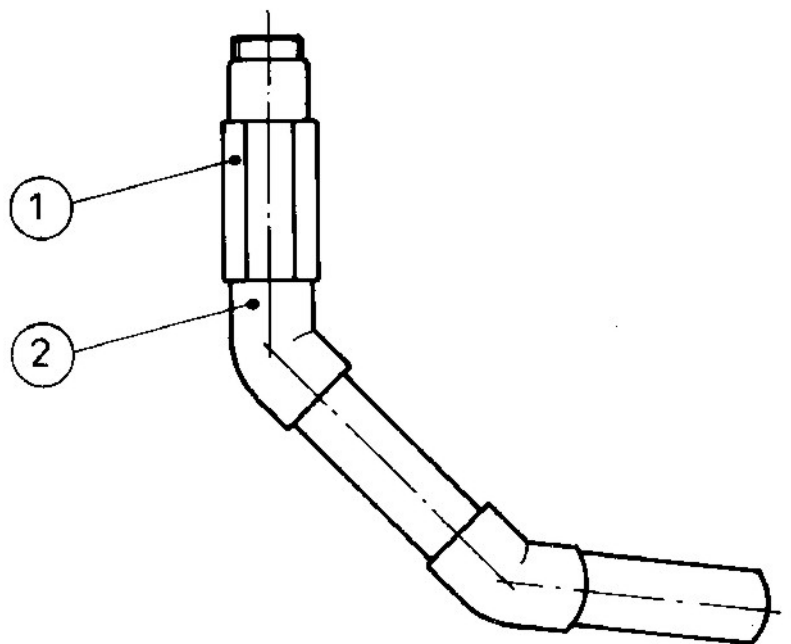

	Pos. and Description	Cat. No.
Fig. 27a Cylinder	Cy Cylinder (Cy)	R3810540

	Pos. and Description	Cat. No.
Fig. 27b Shock Absorber	1 Shock absorber	2GS10001
	2 Top Bracket	381MP321
	3 Bottom Bracket	381MP322
	4 Distance bush	381MP323
	5 Bolt, upper	381MP324
	6 Bolt, lower	381MP325

Fig. 27a Cylinder

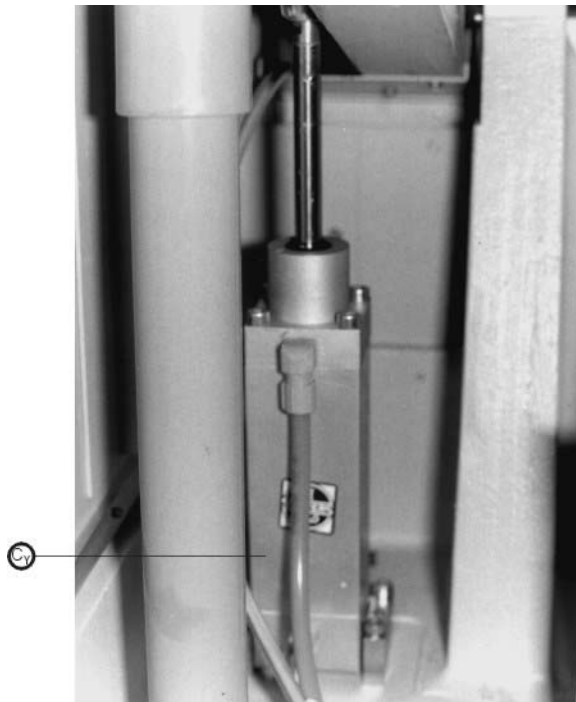
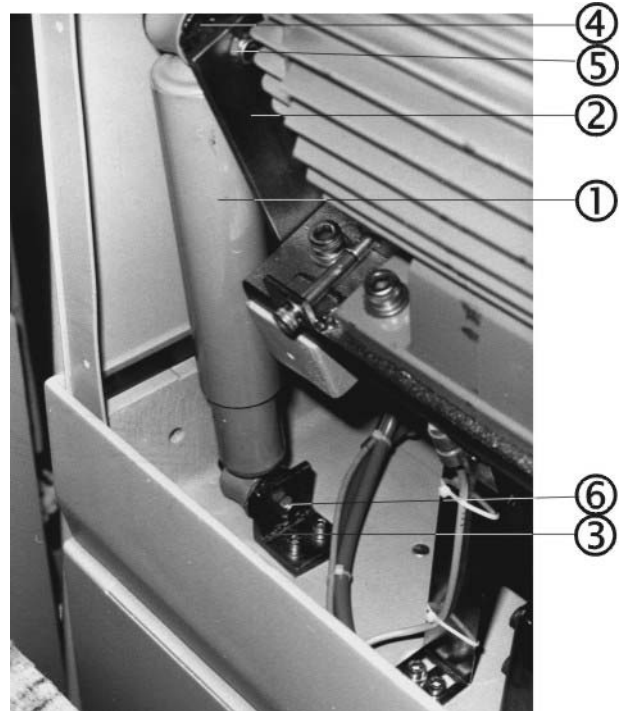

Fig. 27b Shock Absorber



Pos. and Description	Cat. No.
1 Mounting plate for electronics and hydro-pneumatics.....	13819014
Y5 Solenoid valve (Y1, Y2 and Y5).....	381MP183

Fig. 28 Plate for Electronics and Hydro-pneumatics



Pos. and Description	Cat. No.
V3 Water expeller/filter unit, V3	2YF00001
Glass for 381MP189	375MP200

**Fig. 29 Water Expeller/
Filter Unit**

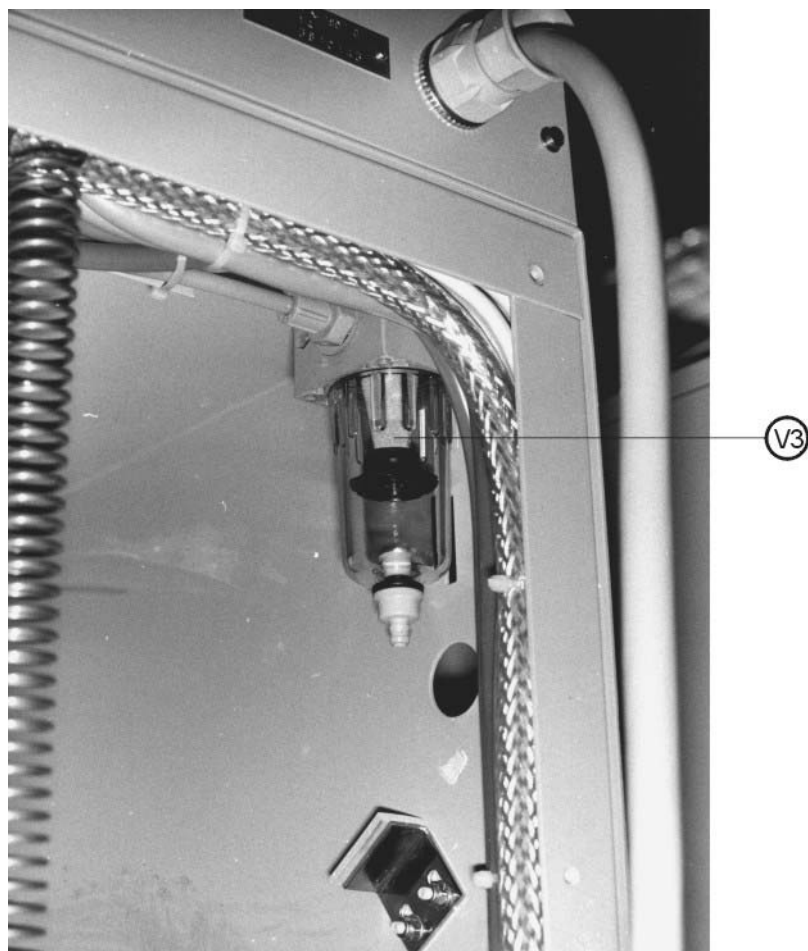

Pos. and Description	Cat. No.
1 Manometer holder	2NS11309
2 Emergency stop switch element, S4	381MP440
V2 Reduction valve	368MP330
V4 Non-return valve (V4)	2YH00012

**Fig. 30 Emergency Stop,
Manometer**

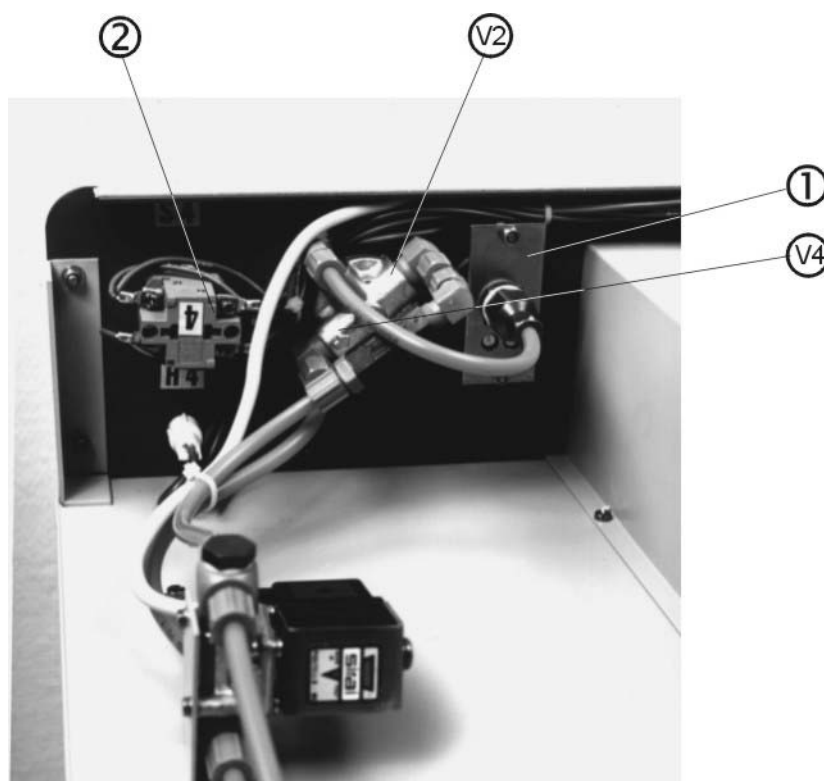

Pos. and Description	Cat. No.
V1 Throttle/one way restrictor valve	2YH00010
1 Angle for valve.....	381MP396
2 Shaft with toothed wheel	381MP397
3 Toothed wheel for valve	13810375

Fig. 31 Throttle Valves

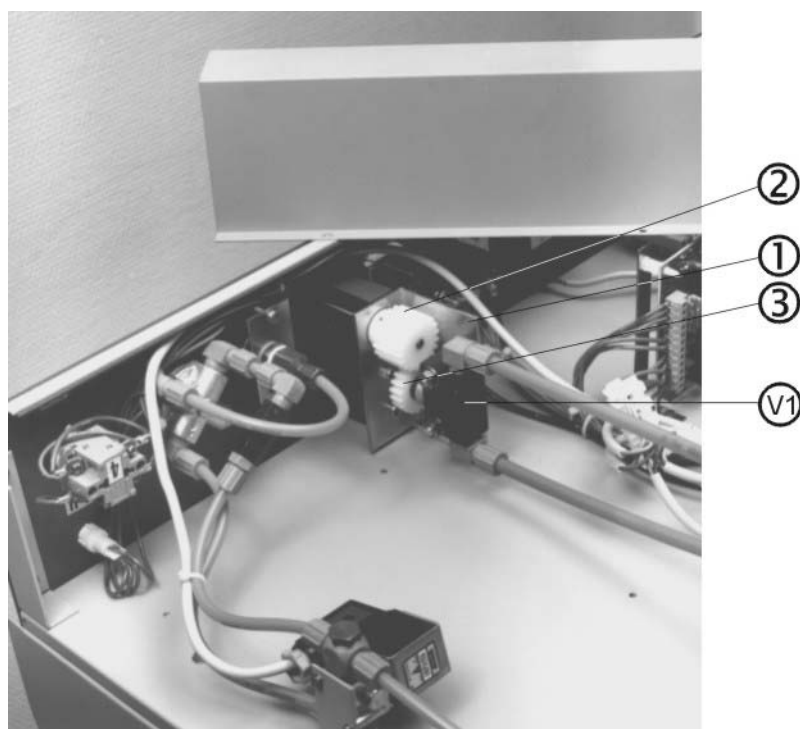

Pos. and Description	Cat. No.
1 Fuse holder, F1, F2	2XS12004
1 Fuse F1, F2	2FU14150
3 Angle for 381MP189	2NF10107
SO Main switch, SO	260MP135

Fig. 32 Main Switch and Fuses



Pos. and Description	Cat. No.
1 Transformer 220V	12601029
1 Transformer, 380-500V	381MP223
4 Contactor, 220V/50-60Hz, K3, K4	2KM10232
4 Contactor, 380-500V/50-60Hz, K3, K4	2KM10232
5 Thermal relay, TI16 0.13-0.20A	381MP345
5 Thermal relay, TI16C 0.13-0.20A	2FS00120
5 Thermal relay, TI16 0.19-0.29A	394MP050A
5 Thermal relay, TI16C 0.19-0.29A	2FS00130
5 Thermal relay, TI16 0.27-0.42A	394MP050A
5 Thermal relay, TI16C 0.27-0.42A	2FS00123
5 Thermal relay, TI16 0.4-0.62A	381MP234
5 Thermal relay, TI16C 0.4-0.62A	2FS00123
5 Thermal relay, TI16 0.6-0.92A	381MP230
5 Thermal relay, TI16C 0.6-0.92A	2FS00124
5 Thermal relay, TI16 4.0-6.2A	2FS00129
5 Thermal relay, TI16C 4.0-6.2A	2FS00129
5 Thermal relay, TI16 6.0-9.2A	381MP233
5 Thermal relay, TI16C 6.0-9.2A	2FS00130
5 Thermal relay, TI16 11-16A	381MP233
5 Thermal relay, TI16C 11-16A	2FS00132
2 Auxiliary switch, NO K2	2KH00111
2 Auxiliary switch, NC K4	2KH00112
Barring device for contactor	2KH10100
Contactors K2, K5, K6 or K7	376MP110
3 Rail	2KM10232
1 Mains/24V-Connector Kit	13812902

Fig. 33 Transformers and Relays

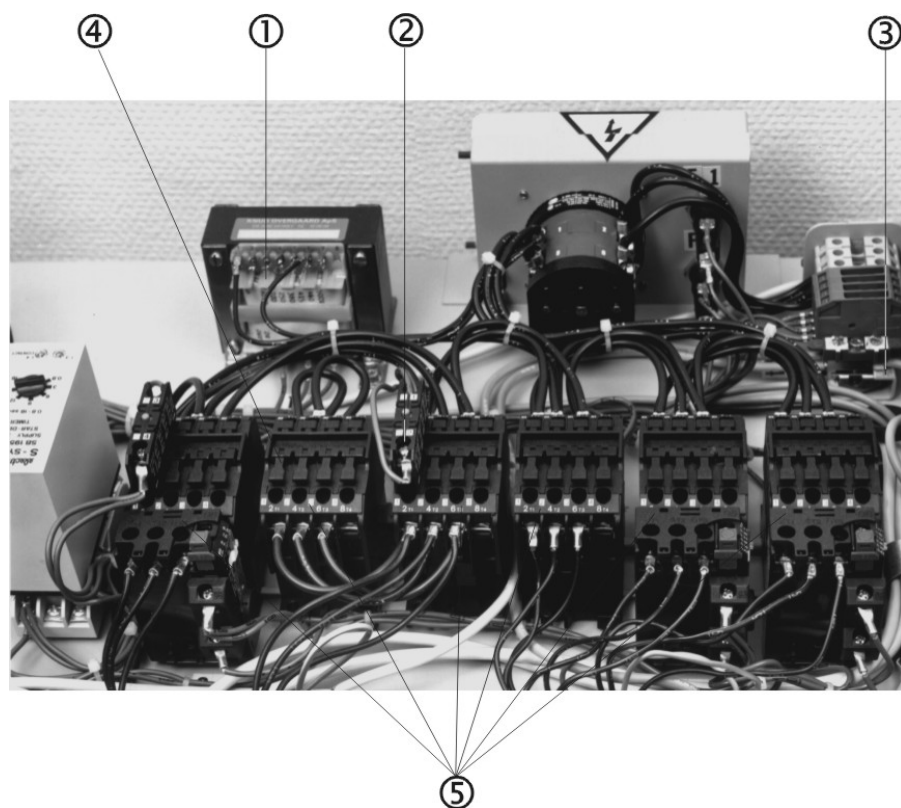

Pos. and Description	Cat. No.
1 Control PCB (Exotom).....	381MP386
Control PCB (Exotom-M).....	14100140
2 Switch element, S1.....	381MP246
3 Switch element, S2, S3.....	381MP247
4 Switch element, S5, S6.....	381MP248
5 Flexible PCB.....	13813376
6 Timer, A2.....	381MP266
Socket for A2.....	2KT90411
7 Angle plate for PCB.....	381MP011
8 Tunnel for hydro-pneumatics.....	13810036
9 Ammeter console.....	381MP015
10 Ammeter, 220V.....	13810232
Ammeter, 380-500V.....	13810233
Bulb, S1, S3, S5, S6, S2.....	2HK13004

Fig. 34 PCB Console

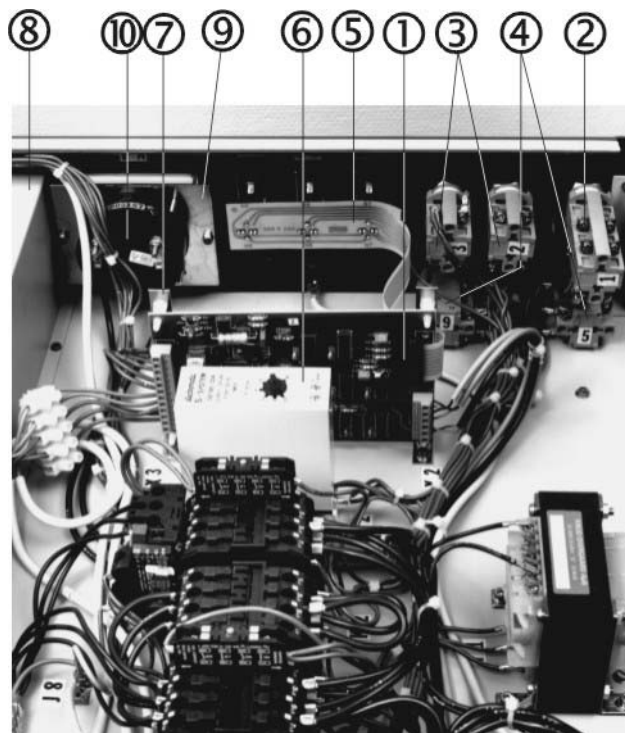

Pos. and Description	Cat. No.
1 Door.....	13819035
2 Locking device	381MP271
3 Distance plate.....	13818039
Vibration damper	13810840
Connection box	381MP274

Fig. 35 Door, Locking Device



Pos. and Description	Cat. No.
1 Arm with bolt.....	381MP391
2 Guide block	381MP392
3 Arm pedestal	13819061
4 Shaft for arm	13810571
5+8 Fork arm for cylinder	13810583
1 Bearing bracket.....	381MP305
7 Shaft for bearing brackets	13810556
Bushing for shaft.....	13810557
Radial flexible bearing for cylinder bottom	381MP443
9 Fitted bolt M10x12x20	2JT11220

Fig. 36 Arm

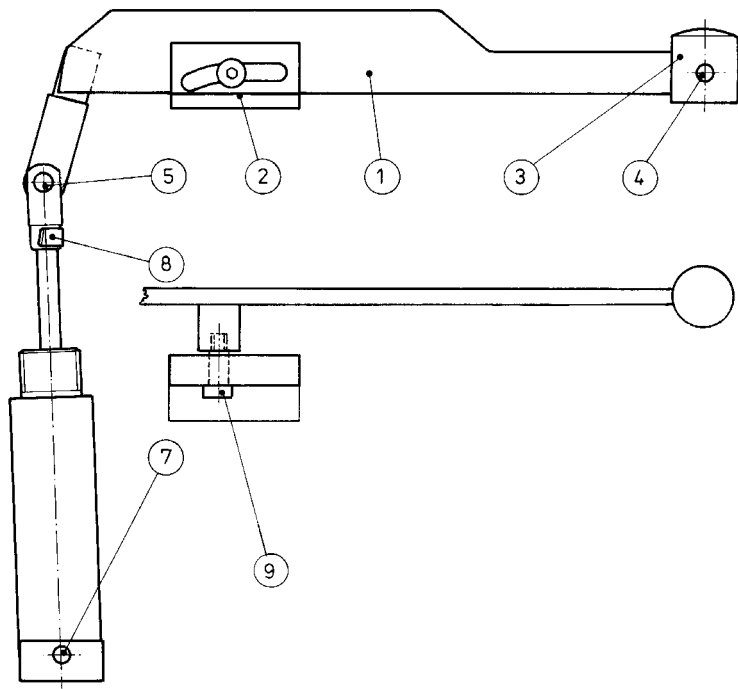

Pos. and Description

Cat. No.

1	V-belts (3 pcs.), 50Hz, L=1202	2JD00002
2	Pulley for cutting motor 50Hz	381MP107
3	Cutting motor 3x200-220V/50Hz.....	381MP210A
	Cutting motor 3x220-220V/60Hz.....	381MP210B
3	Cutting motor 3x380V-415V/50Hz + 3x440V-480V/60Hz.....	381MP211
3	Cutting motor 3x500V/50Hz.....	381MP212

Fig. 37a V-belts

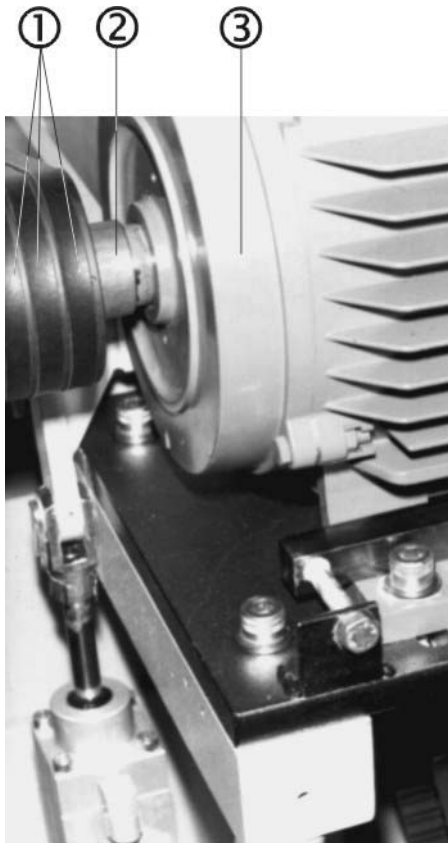
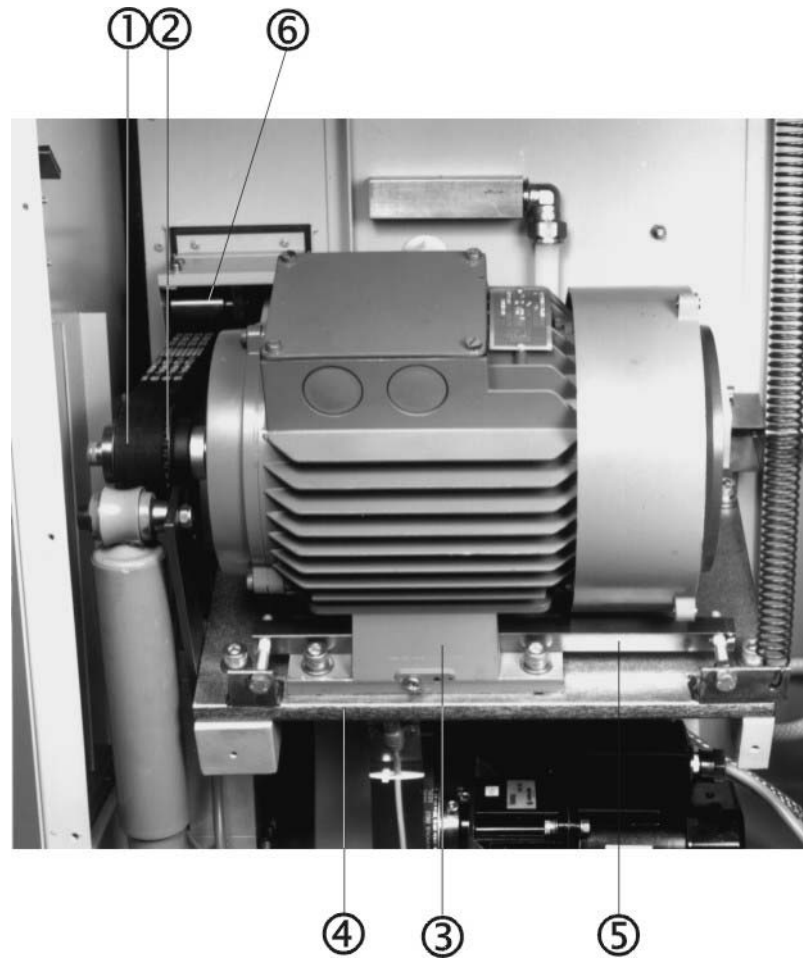

Fig. 38 V-belt Motor, Detail



Pos. and Description	Cat. No.
1 Timing belt, 60Hz 1200-8M-30 RPP.....	2JT11200
2 Pulley for cutting motor, 60Hz	381MP405
4 Motor plate	381MP424
5 Motor base plate/belt tightener	R3818044
6 Idler, complete, 60 Hz	381MP399

Fig. 37b Toothed Belts



Exotom / Exotom-M
Spare Parts and Diagrams

Pos. and Description	Cat. No.
1 Spindle arm with brass bearing and eccentric shaft	381MP060
2 Spindle shaft w. pin	381MPXX13M
3 Ball bearing, 6207-2RS	2BK00107
4 Ball bearing, 6006-2RS	2BK00080
5 Sealing ring, steel.....	13810790
7 Thrust collar	2GF51019
8 Circlip.....	2ZL20550
9 Circlip.....	2ZL10300
10 O-ring (35.1 x 1.6 mm) (10 pcs).....	2IO16030
11 Lock nut	13810792
12 V-belt pulley for spindle, 50 Hz	381MP401
Timing belt pulley for spindle, 60 Hz.....	381MP406
Washer 21/37x3	2ZA10020
Key (A 8x7x36) for pulleys (2 pcs)	2ZF10836
13 Outer ring	13810791
14 Sealing ring	381MP411
15 Washer and screw for spindle.....	381MP450

Fig. 50 Spindle Arm

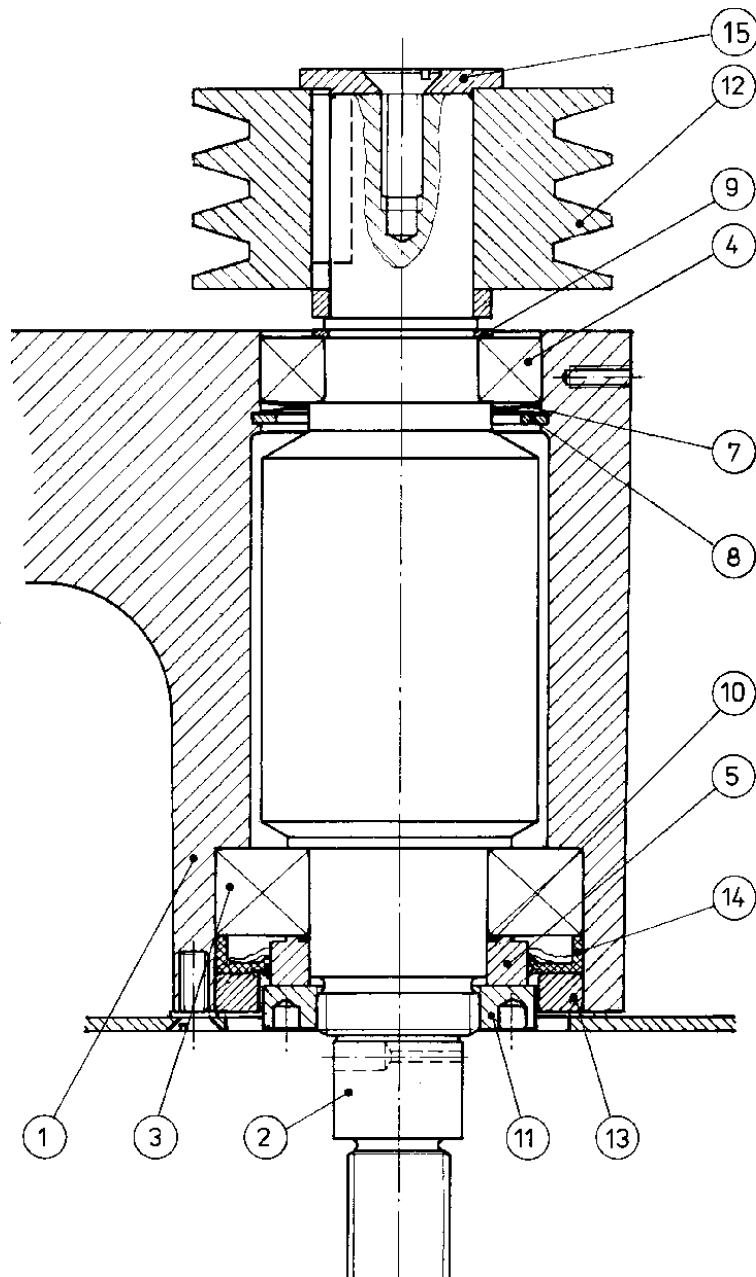

Exotom / Exotom-M
Spare Parts and Diagrams

Pos. and Description	Cat. No.
1 Spindle arm with brass bearing and eccentric shaft	381MP060
2 Eccentric shaft (cannot be ordered separately, part of 381MP60)	
3 Washer with key	13810773
4 Lock nut	2TF02515
5 Lock washer	2ZI02512
6 Distance ring, outer.....	13810770
7 Distance ring with key	381MP376
8 Cover ring	381MP377
10 Ball bearing, 6205-2RS	2BK00055
11 Ball bearing, 6006-2RS	2BK00080
12 Thrust collar (4 pcs.)	2GF51019
13 Circlip.....	381MP098
14 Left arm for motor plate	381MP099
15 Circlip.....	2ZL10250
20 Console for pointer shaft.....	381MP113
21 Pointer shaft	381MP114
22 Distance ring with key	381MP376
23 Grease nipple, type B1, straight (6 mm).....	2GN20002

Fig. 51 Eccentric Shaft

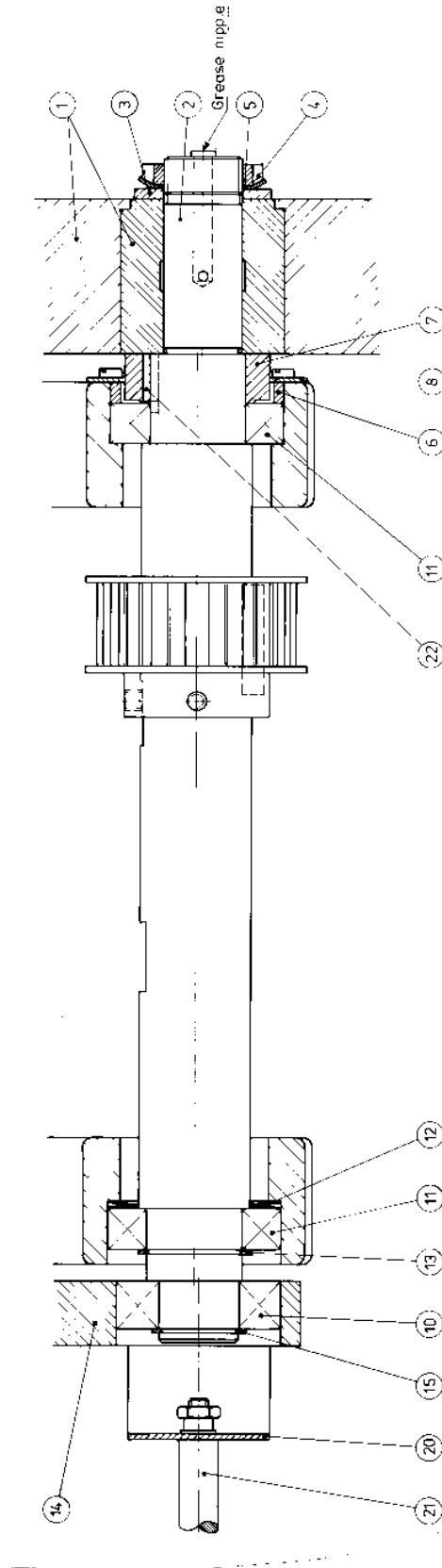

Pos. and Description

Cat. No.

Fig. 51-M Eccentric Shaft,
Exotom-M

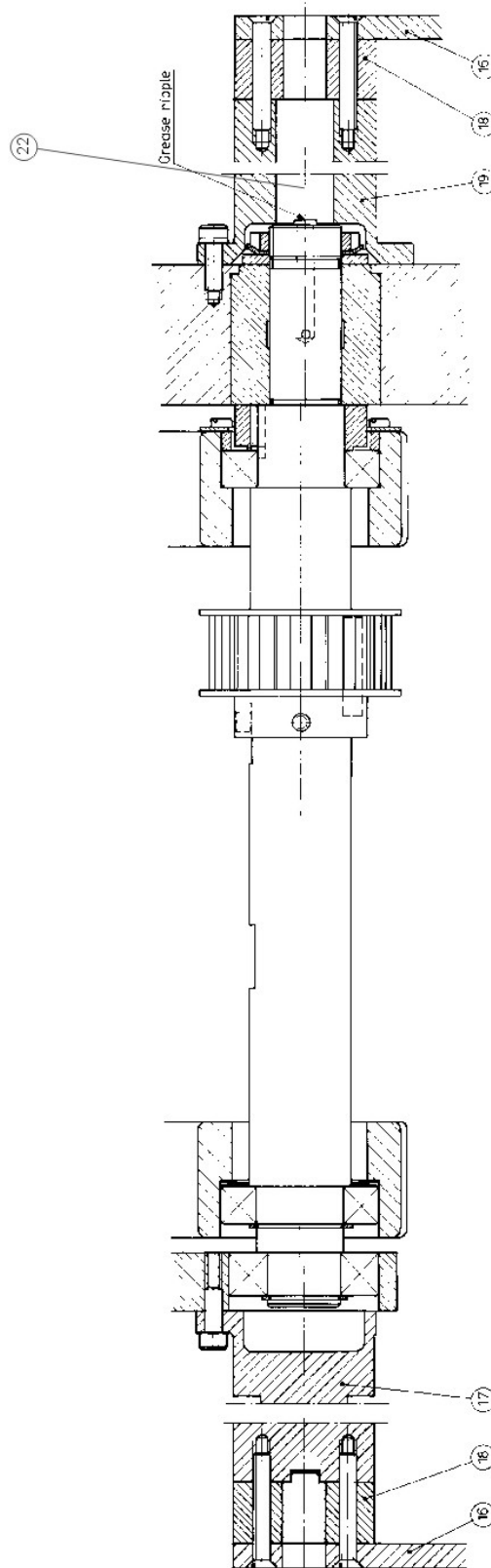

Pos. and Description	Cat. No.
1 Spindle lock case	381MP083
2 Dowel w. circlip	13810439
3 Spring.....	13680095
4 Knob.....	2GH00001

Fig. 52 Spindle Lock Case

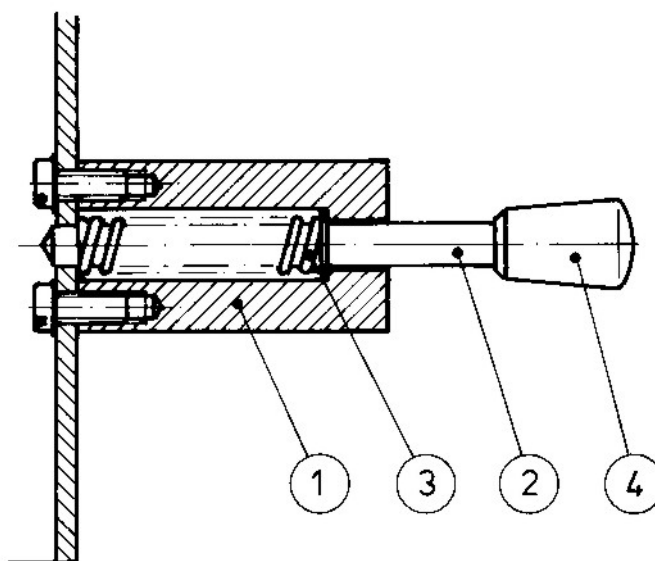

Pos. and Description	Cat. No.
1 Quick-clamping house (cast), right.....	381MP124
2 Quick-clamping house (cast), left	381MP138
3 Guide pin	13810085
4 Handle for guide pin	381MP126
5 Eccentric shaft, complete	15110025
6 Handle rod	13810087
7 Knob	2GH00180
8 Clamping ring (for 2 units)	315MP005
9 Clamping Spring (2 pcs).....	12150155
10 Jaw for QCD, left.....	15330311
11 Jaw for QCD, right.....	15330312
12 Base plate with dowel pins for 10mm T-slots.....	15110027
13 Distance tube.....	2GB01155
14 Pawl (2 pcs).....	381MP134
15 Short T-headed screw with washer and cap nut	381MP135
16 Scraper ring (2 pcs)	2IT00009

Fig. 53 Quick-clamping House

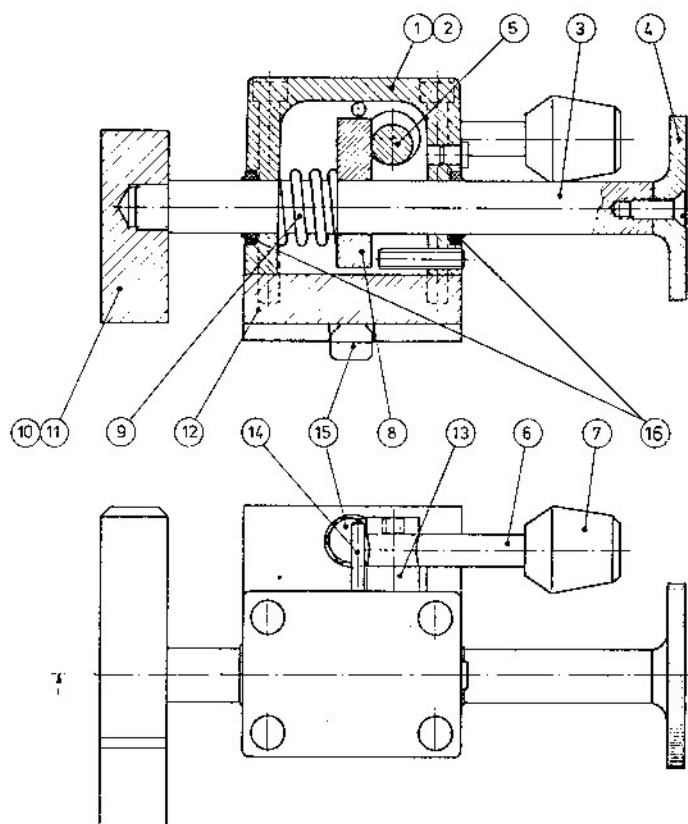

**List of Special Parts
for Exotom-M**

Console for bellow	13810595
Handle	14109002
51M16 Arm for Handle.....	14109001
51M17 Attachment, left.....	14108003
51M18 Guide for arm	14109007
51M19 Attachment, right.....	14109003

See Fig. 10
See Fig. 54

B	Sensor B1, protective screen closed.....	381MP336
1	Control PCB.....	14100140

See Fig. 54

À
À
À

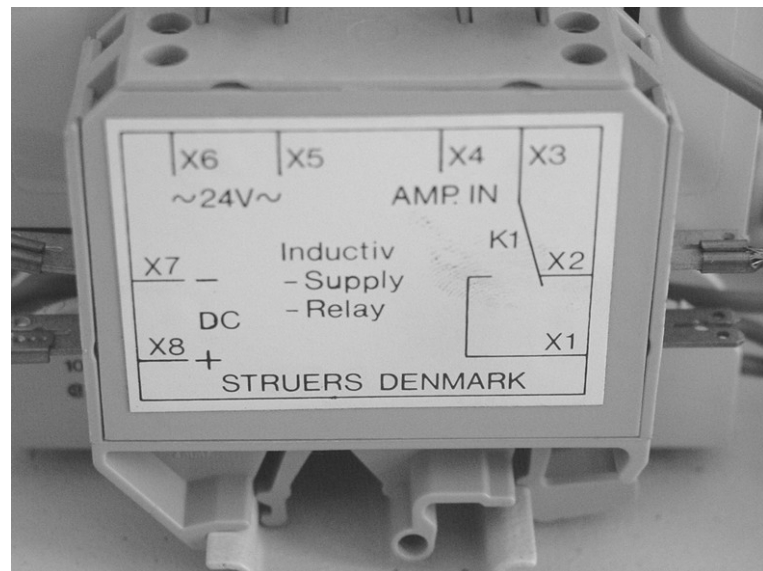

Exotom / Exotom-M
Spare Parts and Diagrams

Diagrams

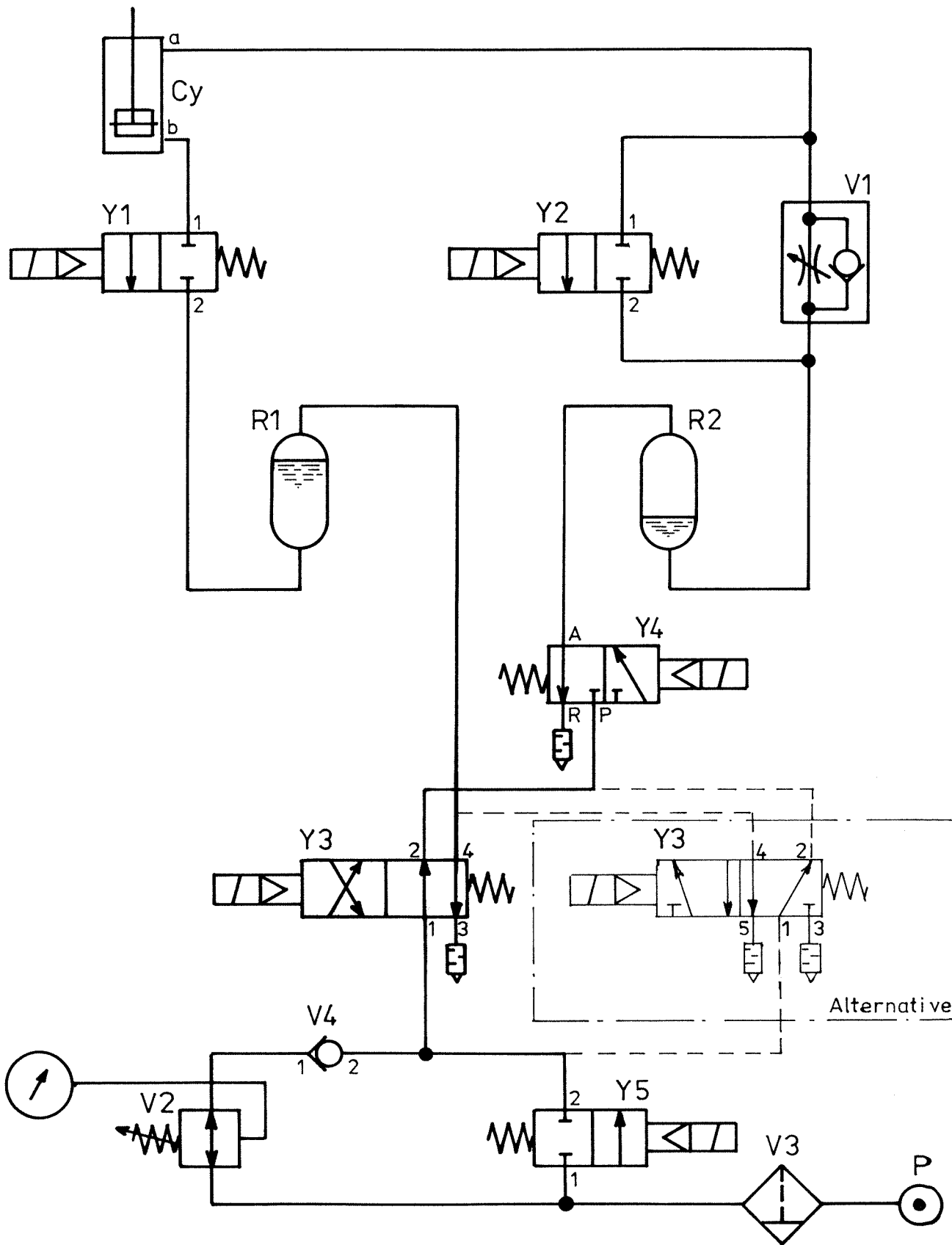

	Matr.	Målestok: Overfladebehandl.:
	STRUERS A/s	
	Kode: Anv. i type:	Navn: B.J/AD Dato 4.11.86 Erst.: 381-11-146
A: Oprindelig Y3 ventil ændret til alternativ 6.8.93 B.J/7TV	Pneumatic diagram for Exotom	13810147 A

MAINS SWITCH

-S0

-W1
L3
L2
L1
PE

-X4: 4 x 4 1/2"
BK3
BK2
BK1

T3
T2
T1

W1
W2
W3

BK3
BK2
BK1

F8 2Amp
F7 2Amp
F6 2Amp

BK12
BK11
BK10

3 x 4 1/2"

J1
YEON

BOTTOM PLANE

Must be short circuit protected with external fuses according to local regulations.
Fuses max.:
200 - 240 Volt. 32 Amp. type gL-gG
380 - 500 Volt. 25 Amp. type gL-gG

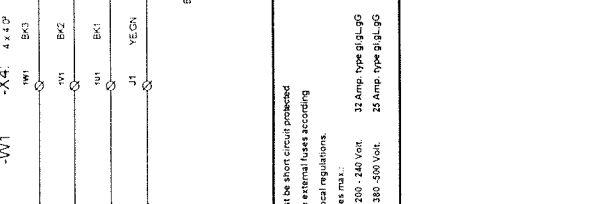
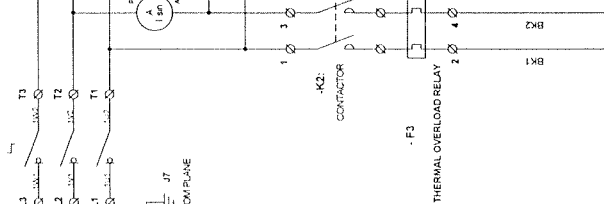
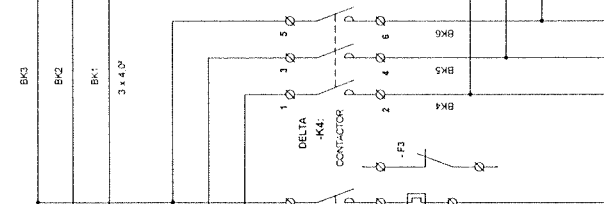
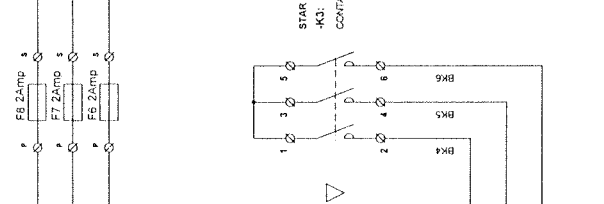
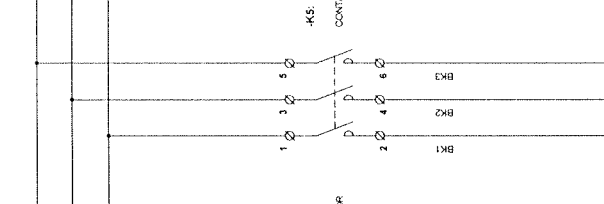
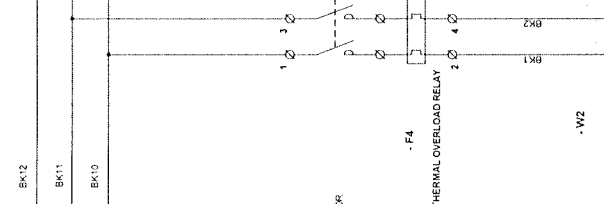
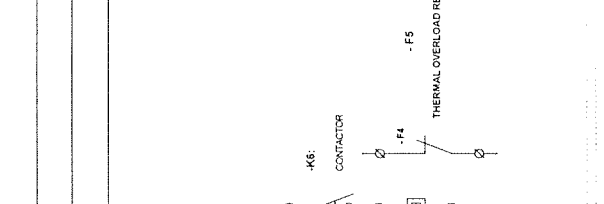
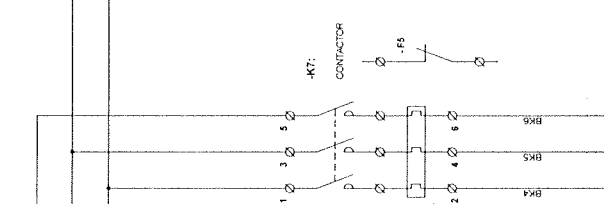
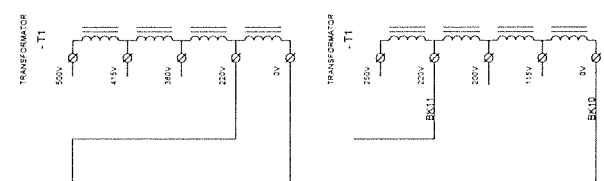

-W6
300-500V 25.5mm²
380-500V 17.5mm²

-W5
300-500V 25.5mm²
380-500V 17.5mm²

-W2
4x1mm²

-W2
4x1mm²

-W3
4x1mm²

-W3
4x1mm²

-W4
4x1mm²

-W4
4x1mm²

BOTTOM PLANE

BOTTOM PLANE

BOTTOM PLANE

BOTTOM PLANE

BOTTOM PLANE

BOTTOM PLANE

BOTTOM PLANE

BOTTOM PLANE

BOTTOM PLANE

YEON

YEON

YEON

YEON

YEON

YEON

YEON

YEON

YEON

YEON

YEON

YEON

YEON

YEON

YEON

YEON

YEON

YEON

YEON

YEON

YEON

YEON

YEON

YEON

YEON

YEON

YEON

YEON

YEON

YEON

YEON

YEON

YEON

YEON

YEON

YEON

YEON

YEON

YEON

YEON

YEON

YEON

YEON

YEON

YEON

YEON

YEON

YEON

YEON

YEON

YEON

YEON

YEON

YEON

YEON

YEON

YEON

YEON

YEON

YEON

YEON

YEON

YEON

YEON

YEON

YEON

YEON

YEON

YEON

YEON

YEON

YEON

YEON

YEON

YEON

YEON

YEON

YEON

YEON

YEON

YEON

YEON

YEON

YEON

YEON

YEON

YEON

YEON

YEON

YEON

YEON

YEON

YEON

YEON

YEON

YEON

YEON

YEON

YEON

YEON

YEON

YEON

YEON

YEON

YEON

YEON

YEON

YEON

YEON

YEON

YEON

YEON

YEON

YEON

YEON

YEON

YEON

YEON

YEON

YEON

YEON

YEON

YEON

YEON

YEON

YEON

YEON

YEON

YEON

YEON

YEON

YEON

YEON

YEON

YEON

YEON

YEON

YEON

YEON

YEON

YEON

YEON

YEON

YEON

YEON

YEON

YEON

YEON

YEON

YEON

YEON

YEON

YEON

YEON

YEON

YEON

YEON

YEON

YEON

YEON

YEON

YEON

YEON

YEON

YEON

YEON

YEON

YEON

YEON

YEON

YEON

YEON

YEON

YEON

YEON

YEON

YEON

YEON

YEON

YEON

YEON

YEON

YEON

YEON

YEON

YEON

YEON

YEON

YEON

YEON

YEON

YEON

YEON

YEON

YEON

YEON

YEON

YEON

YEON

YEON

YEON

YEON

YEON

YEON

YEON

YEON

YEON

YEON

YEON

YEON

YEON

YEON

YEON

YEON

YEON

YEON

YEON

YEON

YEON

YEON

YEON

YEON

YEON

YEON

YEON

YEON

YEON

YEON

YEON

YEON

YEON

YEON

YEON

YEON

YEON

YEON

YEON

YEON

YEON

YEON

YEON

YEON

YEON

YEON

YEON

YEON

YEON

YEON

YEON

YEON

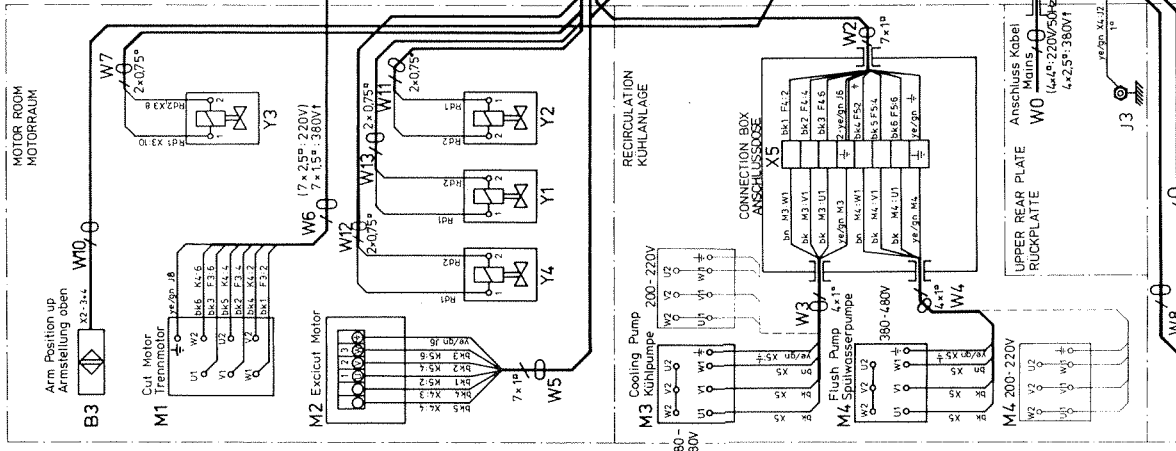
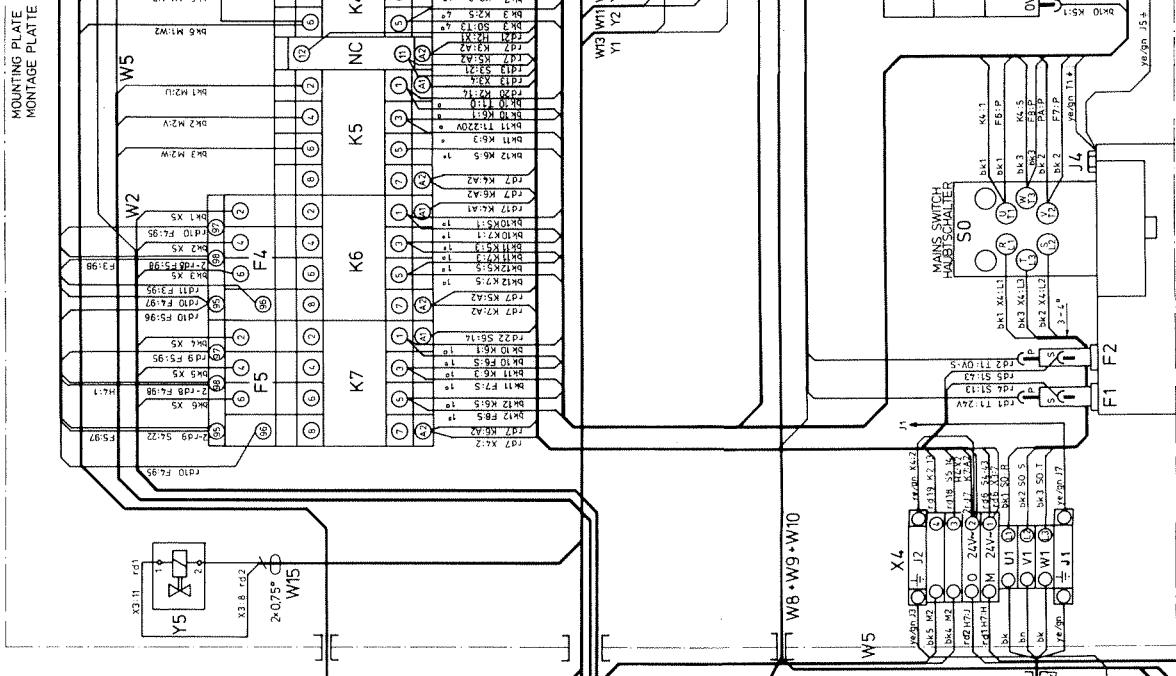
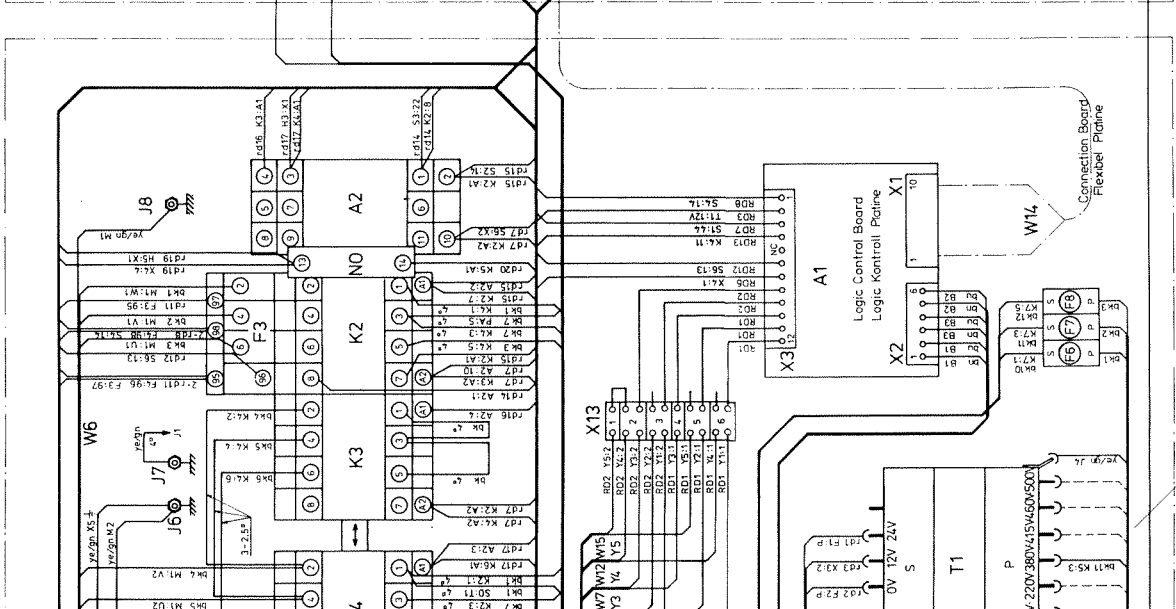
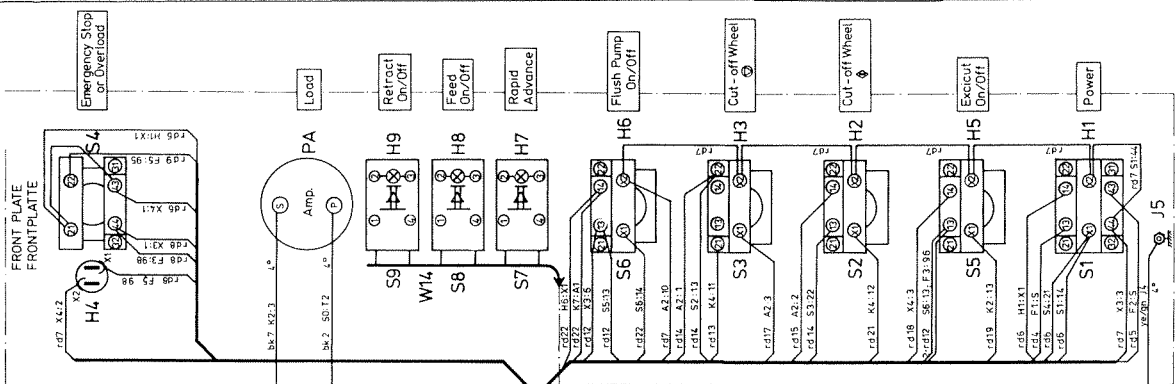

- ØB = black
- BK = black
- BR = brown
- BL = blue
- RD = red
- OR = orange
- VE = yellow
- GR = green
- GN = grey
- BL = blue
- GR = grey
- WH = white
- PK = pink
- BR = beige

All red wirings 1°
Alle rote leitungen 1°

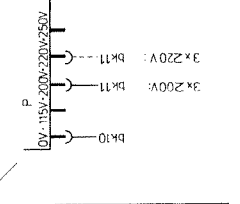

Motor protection, fuse setting
Motor schutz Einstellung

U/I	F3	F4	F5
200-220/50	19A	0.71A	0.38A
200-220/60	19A	0.44A	0.38A
380/50	11.5A	0.41A	0.22A
380/60	11.5A	0.25A	0.22A
415/50	11.5A	0.41A	0.22A
430/60	11.5A	0.25A	0.22A
490/60	14.5A	0.25A	0.22A
500/50	9A	0.31A	0.18A

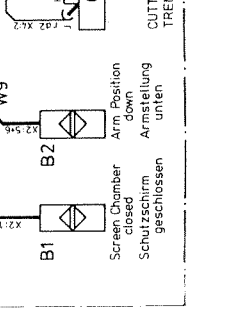
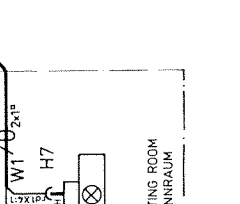
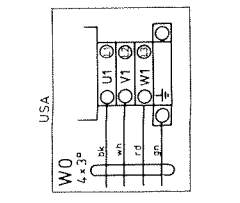

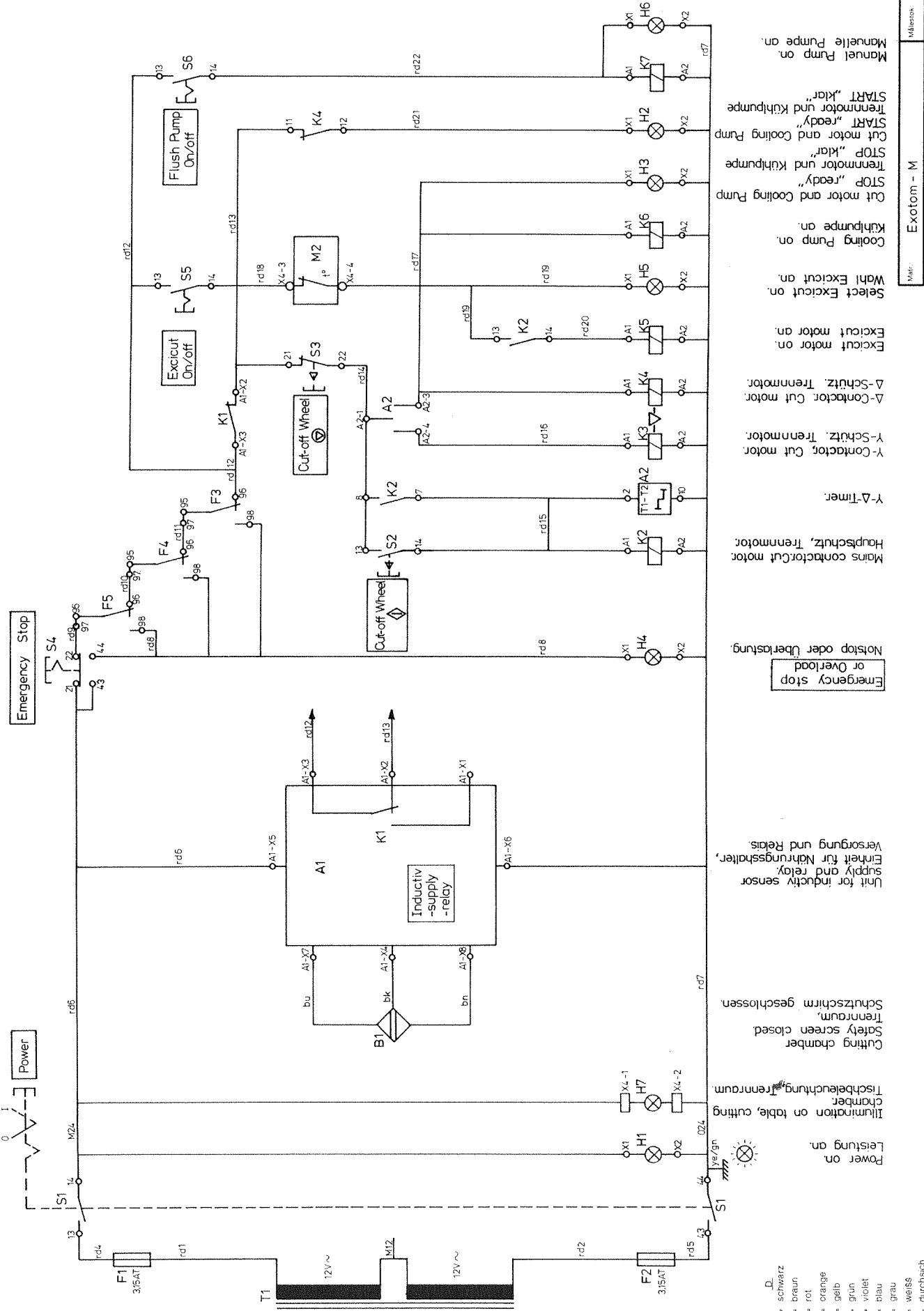

- SB = black
- bk = schwarz
- br = brown
- brn = braun
- rd = red
- rot = rot
- or = orange
- or = orange
- ye = yellow
- gelb = gelb
- gn = green
- grn = grün
- vt = violet
- violet = violett
- bl = blue
- blau = blau
- gy = grey
- grau = grau
- wh = white
- weiss = weiss
- tr = transp.
- durchsich = durchsichtig
- pk = pink
- rosa = rosa
- be = beige
- beige = beige

Power on.
Leistung an.

Chamber illumination on table, cutting.
Tischbeleuchtung/Trennum.

Cutting chamber safety screen closed.
Trennum, Schutzschirm geschlossen.

Unit for inductive sensor supply and relay.
Einheit für Induktivsensor, Versorgung und Relais.

Emergency stop or Overload.
Notstop oder Überlastung.

Main contactor cut motor.
Hauptschutz, Trennmotor.

Y-Δ timer.

Y-Contact, Cut motor.
Y-Schutz, Trennmotor.

Δ-Contact, Cut motor.
Δ-Schutz, Trennmotor.

Excite motor on.
Excit motor an.

Excite motor on.
Excit motor an.

Select Excite on.
Wahl Excit an.

Cooling Pump on.
Kühlpumpe an.

STOP "ready" and Cooling Pump.
Trennmotor und Kühlpumpe STOP "klar".

Cut motor and Cooling Pump.
Cut motor and Cooling Pump START "ready".

START "klar".
Trennmotor und Kühlpumpe START "klar".

Manuelle Pumpe an.
Manuelle Pumpe an.

№Место:	№Место:
Наим: С/З 81б.	Наим: С/З 81б.
Дат: 10-10-85	Дат: 10-10-85
Состав: 4-12-17-18-19-20-21-22	Состав: 4-12-17-18-19-20-21-22
STRUERS A/s	
Exotom - M	
Control Circuit Diagram.	
Kontrollkreislauf Diagramm.	
14100111D	

D: Tom. At kl. ved F. H. P. 15 84 84
 C: S. H. Nye Jensen, 176 NY Østvej
 B: K/S Smørum, 4610, Sønderhojvej
 A: Jørgensen, 4610 Sønderhojvej

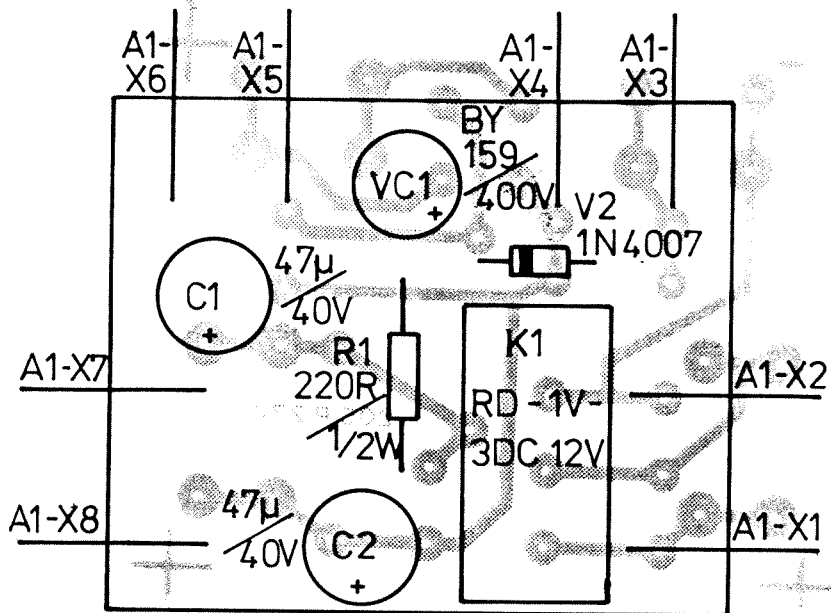

X1 - X8 pin connectors Weidmüller S6,3 no.49610

Ikke ang. ruheder:	✓
Ikke ang. tolerancer:	±
Målestok:	
Navn:	B.J./ MB
Dato:	14.10.85
Erstatter:	381-17-1610
14100155	

Matr...

STRUERS A/s

Anvendes i type:

Component illustration
for Exotom - M

Dansk

Overensstemmelseserklæring

 Struers

Fabrikant Struers A/S
Valhøjs Allé 176,
DK-2610 Rødovre, Danmark
Telefon 36 70 35 00

erklærer herved, at

<i>Produktnavn:</i>	Exotom
<i>Type nr.:</i>	381
<i>Maskintype:</i>	Skæremaskine

er i overensstemmelse med følgende EU-direktiver:

Maskindirektivet 89/392/EØF, 91/368/EØF, 93/44/EØF og 93/68/EØF efter følgende norm(er):
EN292-1:1991, EN292-2:1993/A1:1995, EN294:1993, EN349:1994, EN418:1994, EN954-1:1997,
EN1037:1996, EN11200:1996, EN60204-1:1997:ED4.

EMC-direktivet 89/336/EØF og 92/31/EØF efter følgende norm(er):
EN50081-1:1991, EN50081-2:1993, EN50082-1:1992, EN50082-2:1994.

Lavspændingsdirektivet 73/23/EØF og efter følgende norm(er):
EN60204-1:1997:ED4.

Supplerende oplysninger Endvidere overholdes de amerikanske normer:
NEPA 79-1997, UL508 ED14 22-2-88.

Ovenstående overensstemmelse(r) er erklæret iflg. den globale metode, modul A

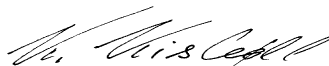

Dato: 20.01.1999

Klaus Kisbøll, udviklingschef, Struers A/S

English

Declaration of Conformity

 Struers

Manufacturer Struers A/S
Valhøjs Allé 176
DK-2610 Rødovre, Denmark
Telephone 36 70 35 00

Herewith declares that

<i>Product Name:</i>	Exotom
<i>Type No:</i>	381
<i>Machine Type:</i>	Cut-off machine

is in conformity with the provisions of the following directives:

Safety of Machinery 89/392/EEC, 91/368/EEC, 93/44/EEC and 93/68/EEC according to the following standard(s):
EN292-1:1991, EN292-2:1993/A1:1995, EN294:1993, EN349:1994, EN418:1994, EN954-1:1997,
EN1037:1996, EN11200:1996, EN60204-1:1997:ED4.

EMC-Directive 89/336/EEC and 92/31/EEC according to the following standard(s):
EN50081-1:1991, EN50081-2:1993, EN50082-1:1992, EN50082-2:1994.

Low Voltage Directive 73/23/EEC according to the following standard(s):
EN60204-1:1997:ED4.

Supplementary Information The equipment complies with the American standards:
NEPA 79-1997, UL508 ED14 22-2-88.

The above has been declared according to the global method, module A

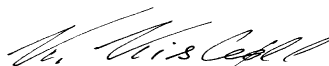

Date: 20.01.1999

Klaus Kisbøll, R&D Manager, Struers A/S

Deutsch

Konformitätserklärung

 Struers

Hersteller Struers A/S
Valhøjs Allé 176,
DK-2610 Rødovre, Danmark
Telefon 36 70 35 00

erklärt hiermit, daß

<i>Produktname:</i>	Exotom
<i>Typennr.:</i>	381
<i>Maschinenart:</i>	Trennmaschine

konform ist mit den einschlägigen EG-Richtlinien

Sicherheit der Betriebsanlage 89/392/EWG, 91/368/EWG, 93/44/EWG, und 93/68/EWG gemäß folgender Normen:
EN292-1:1991, EN292-2:1993/A1:1995, EN294:1993, EN349:1994, EN418:1994, EN954-1:1997,
EN1037:1996, EN11200:1996, EN60204-1:1997:ED4.

EMC-Direktive 89/336/EWG und 92/31/EWG gemäß folgender Normen:
EN50081-1:1991, EN50081-2:1993, EN50082-1:1992, EN50082-2:1994.

Niederspannungs - Direktive 73/23/EWG gemäß folgender Normen:
EN60204-1:1997:ED4.

Ergänzungs-information Die Maschine entspricht ebenfalls den amerikanischen FCC Normen:
NEPA 79-1997, UL508 ED14 22-2-88.

Die obenstehende Konformität ist in Folge der globalen Methode, Modul A erklärt

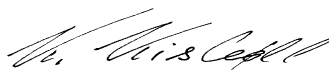

Datum: 20.01.1999

Klaus Kisbøll, Entwicklungsleiter, Struers A/S

Français

Déclaration de conformité

 Struers

Fabricant Struers A/S
Valhøjs Allé 176
DK-2610 Rødovre, Denmark
Téléphone 36 70 35 00

Déclare ci-après que

<i>Nom du produit:</i>	Exotom
<i>Type no:</i>	381
<i>Type de machine:</i>	Machine pour le tronçonnage

est conforme aux dispositions des Directives CEE suivantes:

Sécurité des machines 89/392/CEE, 91/368/CEE, 93/44/CEE et 93/68/CEE conforme aux normes suivantes:
EN292-1:1991, EN292-2:1993/A1:1995, EN294:1993, EN349:1994, EN418:1994, EN954-1:1997,
EN1037:1996, EN11200:1996, EN60204-1:1997:ED4.

Directive EMC 89/336/CEE et 92/31/CEE conforme aux normes suivantes:
EN50081-1:1991, EN50081-2:1993, EN50082-1:1992, EN50082-2:1994.

Directive de basse tension 73/23/CEE conforme aux normes suivantes:
EN60204-1:1997:ED4.

Informations supplémentaires L'équipement est conforme aux standards américains:
NEPA 79-1997, UL508 ED14 22-2-88.

La déclaration ci-dessus a été faite d'après la méthode globale, module A

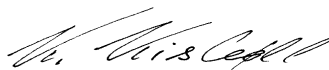

Date: 20.01.1999

Klaus Kisbøll, Chef du service developpement, Struers A/S