

# Xmatic Compact

## Pre-installation checklist



CE

Doc. no.: 16887037\_C\_en-us  
Date of release: 2023.02.28

---

**Copyright**

The contents of this manual are the property of Struers ApS. Reproduction of any part of this manual without the written permission of Struers ApS is not allowed.

All rights reserved. © Struers ApS 2023.02.28.

# 1 Installation requirements

- Forklift truck
- Electrical power supply cable according to local regulations
- External short circuit protection
- Compressed air supply
- Exhaust system
- Water supply
- Drain

## **Accessories and consumables**

*Required accessories and consumables that have been ordered separately.*

The use of Struers consumables is recommended.

- Diamond discs, Preparation discs
- Specimen holder
- Suspensions, lubricants

For information about the available range, see:

- [The Xmatic Compact brochure](https://www.struers.com) (https://www.struers.com)
- [The Struers Consumables Catalogue](https://www.struers.com) (via https://www.struers.com)

## *Recommended accessories*

- Recirculation unit
- Additive for recirculation unit
- Beacon

## 2 Packaging specifications

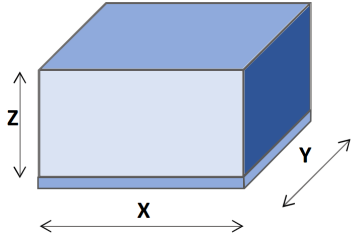
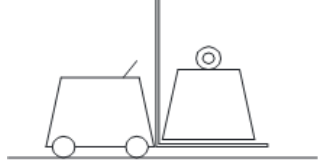
<b>X:</b>	210 cm (83")	
<b>Y:</b>	108 cm (43")	
<b>Z:</b>	220 cm (87")	
<b>Weight</b>	<p>730 kg (1609 lbs). The weight is stated on the crate.</p> <p>The weight depends on the configuration of the machine.</p>	

## 3 Location

Distance from the floor to the following units	
Emergency stop	1070 mm (43")
Front panel	1300 mm (52")
Display	1410 mm (56")
Main safety cover handle (open/closed)	Open: 1370 mm (54") Closed: 1060 mm (42")

### Illumination

Make sure that the machine is adequately lit up. A minimum of 300 Lumen is recommended to illuminate the controls and other work areas.

Ambient conditions		
Operating environment	Surrounding temperature	5-40°C (40-105°F)
	Humidity	35-85 % RH non-condensing

# 4 Dimensions

Front view - without vertical conveyor		
<b>A:</b>	Height 1900 mm (75") With open cover: 2350 mm (93") With beacon: 2260 mm (89")	
<b>B:</b>	Width 1490 mm (59")	

Front view - with vertical conveyor		
<b>A:</b>	Height 1900 mm (75") With open cover: 2350 mm (93") With beacon: 2260 mm (89")	
<b>B:</b>	Width 1820 mm (72")	

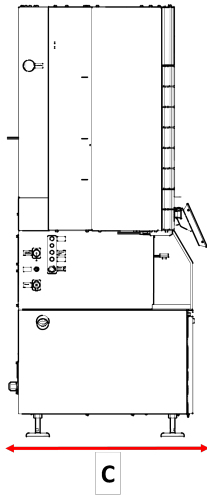
Side view	
<p><b>C:</b> Depth 750 mm (30")</p>	 <p>The diagram shows a side view of the Xmatic Compact machine. A red double-headed arrow at the bottom indicates the depth dimension, labeled 'C'. The machine has a control panel on the right side and a main body with a door on the left. The depth is measured from the front edge to the back edge.</p>

## 5 Recommended space

### Space in front of the machine

- Make sure that there is enough room in front of the machine. 100 cm (40")

### Space at the sides of the machine

- Recommended space at the sides of the machine. 100 cm (40")
- Make sure that there is enough room at the left side of the machine for access to the compressed air and water connections

### Space at the rear of the machine

- The machine can be placed against a wall.
- Make sure that there is enough space for the main power cable.

## 6 Unpack the machine

**Note**

We recommend that you keep all original packaging and fittings for future use.

**Remove the packing box**

- Open and remove the sides and the top of the packing box.

**Remove the transport brackets**

- Unscrew the transport brackets that secure the machine to the pallet.

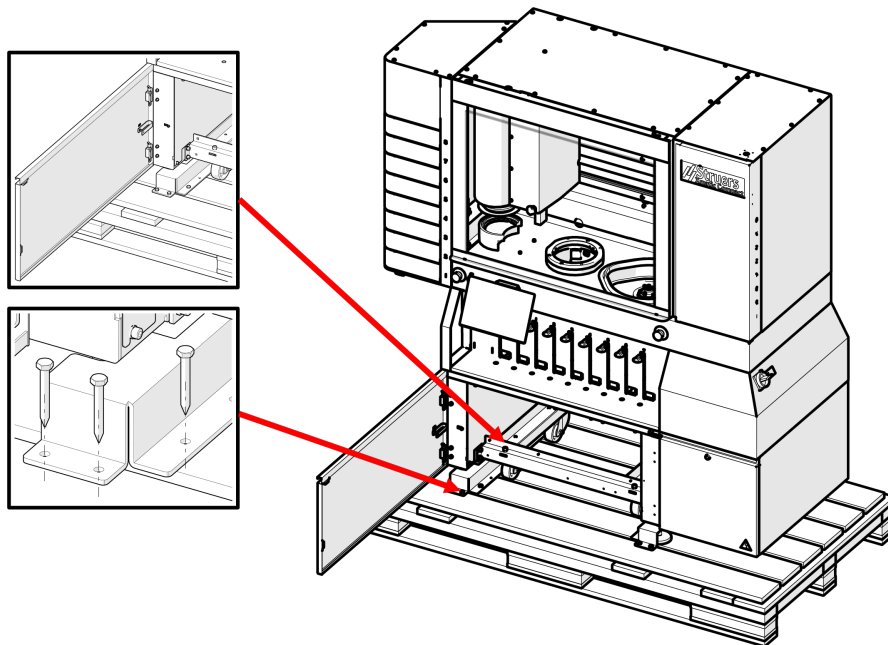

## 7 Transport and storage

If, at any time after the installation, you have to move the unit or place it in storage, there is a number of guidelines we recommend that you follow.

- Package the unit securely before transportation. Insufficient packaging could cause damage to the unit and will void the warranty. Contact Struers Service.
- We recommend that you use the original packaging and fittings.

## 7.1 Preparing for transport and storage



**Note**  
We recommend that you keep all original packaging and fittings for future use.

1. Make sure that packaging (screws and plywood) is available for building a crate to cover the machine.
2. Position the machine on the blocks on the original pallet.  
The blocks lift the wheels from the pallet.
3. Use the transport brackets to secure the machine to the pallet.
4. Place the machine and accessories in their original packaging.
5. Build the original crate around the machine.

## 7.2 Transport

To transport the machine safely, follow these instructions.

1. Make sure that the following items are available:
  - Transport brackets (x 2)
  - Transport crossbar (x 1)
  - Bar with wheels (x 2)
  - The original pallet
2. If needed, disconnect the following:
  - Power supply



**ELECTRICAL HAZARD**  
Disconnecting the unit from the electrical power supply must only be done by a qualified technician.

- Compressed air supply
  - Water supply
  - Recirculation unit. See the manual supplied with the specific equipment.
  - Disconnect the monitor. This must be done by StruersService.
  - Accessories
3. Clean and dry the unit.

### Requirements

- Make sure that the floor of the working area and the transportation corridor are designed to carry the weight of the machine.

<b>Weight</b>	
Machine	730 kg (1609 lbs)



**Moving the machine****Note**

The machine must be installed by Struers technicians or by an authorized service technician trained by Struers for this specific task.

**7.3 Storage**

- Disconnect the unit from the electrical power supply.
- Disconnect the unit from the water supply.
- Disconnect the unit from the compressed air supply.
- Disconnect the unit from the drain.
- Remove any accessories.
- Clean and dry the unit before storage.
- Place the machine and accessories in their original packaging.

**7.4 Lift the machine****CRUSHING HAZARD**

Take care of your fingers when handling the machine.  
Wear safety shoes when handling heavy machinery.

Weight	
Machine	730 kg (1609 lbs)

### Center of gravity

Front view

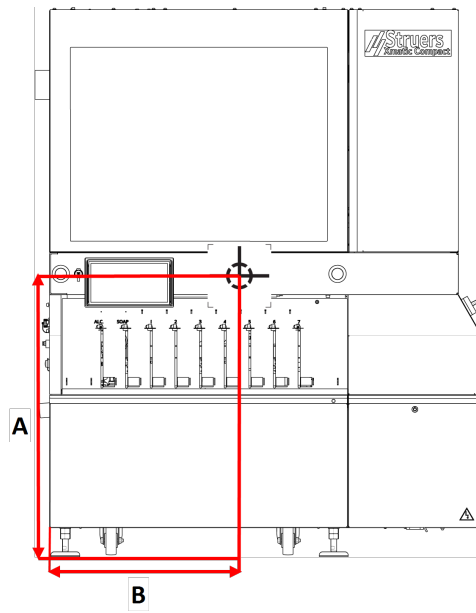

**A:** 1000 mm (40")  
**B:** 845 mm (34")

Side view

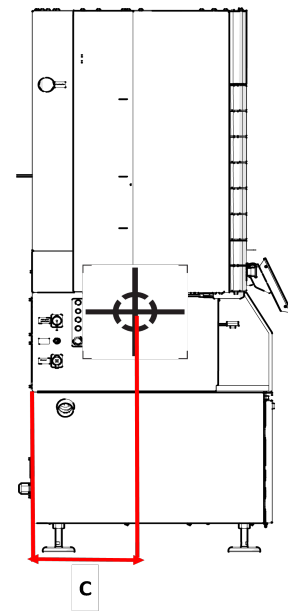

**C:** 300 mm (12")

Front view with vertical conveyor

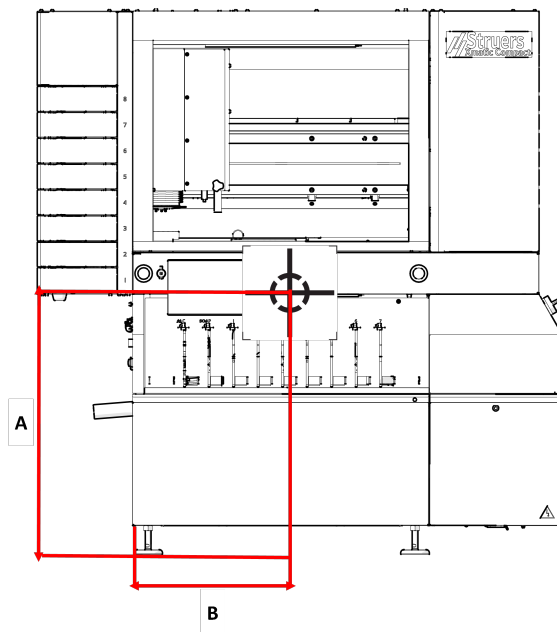

Side view with vertical conveyor

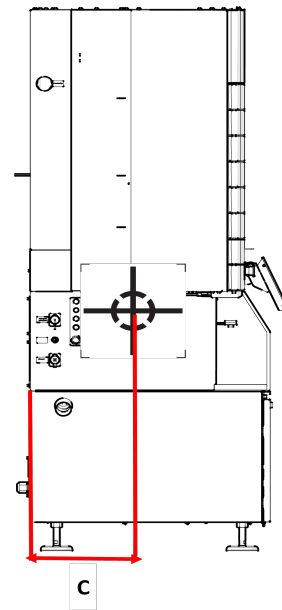

**A:** 1000 mm (40")

**B:** 1200 mm (48")

**C:** 300 mm (12")

#### Lift the machine from the pallet with a forklift

1. Loosen the adjustable feet. Make sure that the feet are positioned higher than the wheels.
2. Loosen and remove the transport brackets.

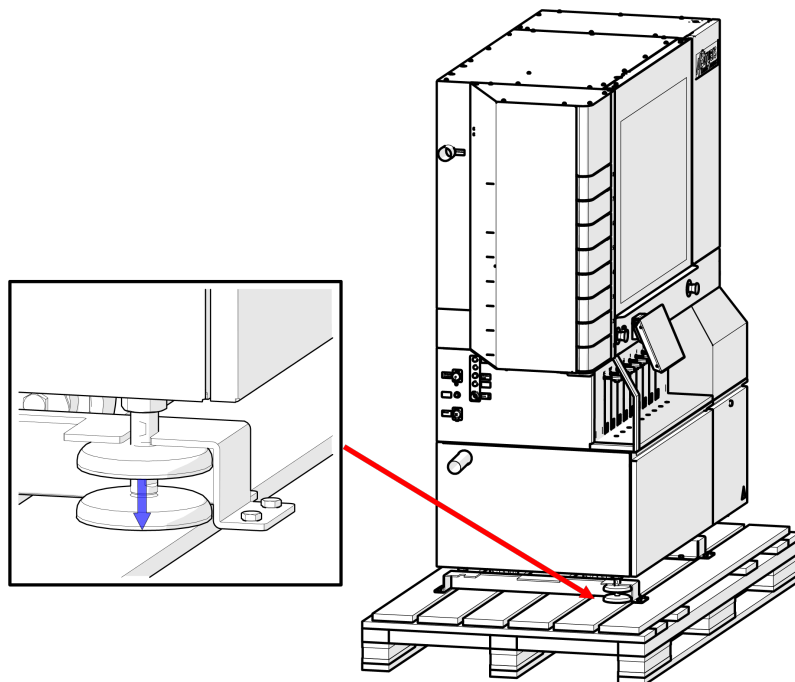

3. Place the forks so that the center of gravity is placed between the forks. Lift the machine from the front.
4. Lift the machine off the pallet.

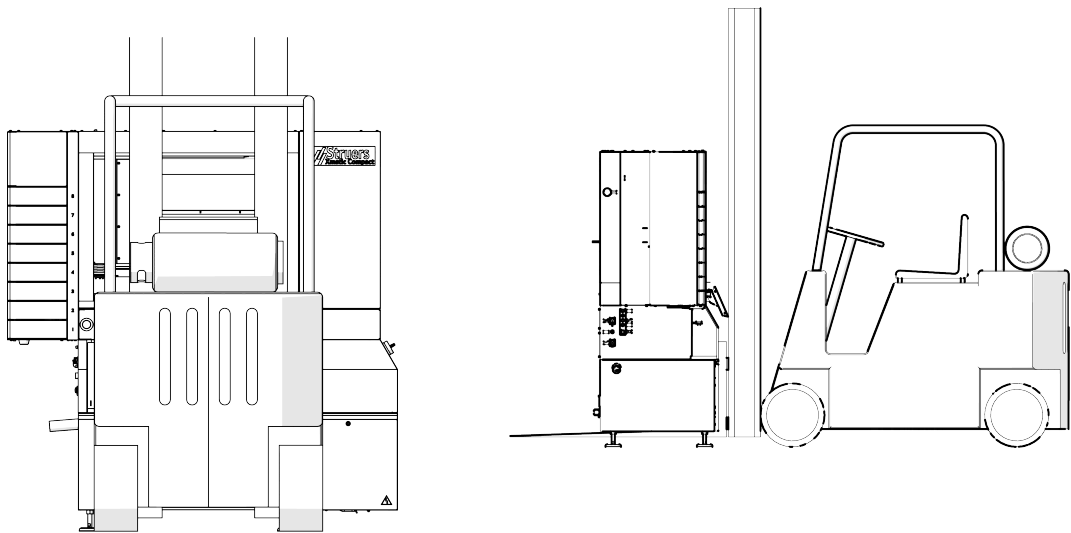

### Note

Place the machine on a plane and horizontal floor.

## 7.5 At the final location

### Push the machine into position



### CAUTION

The machine must not operate when it is resting on its wheels.



### CAUTION

Make sure that the machine is level.

1. If you cannot place the machine directly in its location, turn the adjustable feet upwards to stand the machine on its wheels.
2. Move the machine to its final position.
3. Lower the machine so that the feet touch the floor.
4. Turn the adjustable feet until the machine rests on the feet, and make sure that the machine is level.
5. Remove the transportation crossbar and store it for future use. See also: [Remove the transportation crossbar ▶ 13](#). The wheels of the machine cannot swivel when the crossbar is mounted.
6. Remove the transport screws on the counter weight and store for future use. See also: [Remove the counterweight screws on the rear side of the machine ▶ 13](#).

**Remove the transportation crossbar**

1. Remove the wheels and the transportation crossbar supplied with the machine.
2. Store the crossbar for future use.

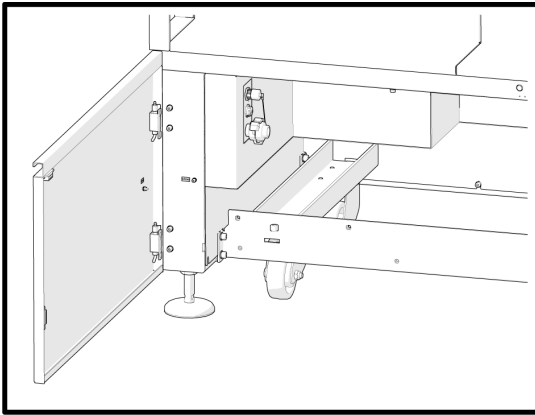

Machine with crossbar

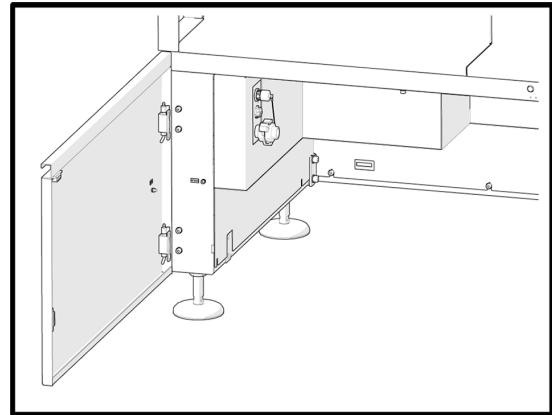

Machine without crossbar

**Remove the counterweight screws on the rear side of the machine**

Once the machine is placed in its final location:

- Use a 5 mm Allen key to remove the counterweight screws on the rear side of the machine.

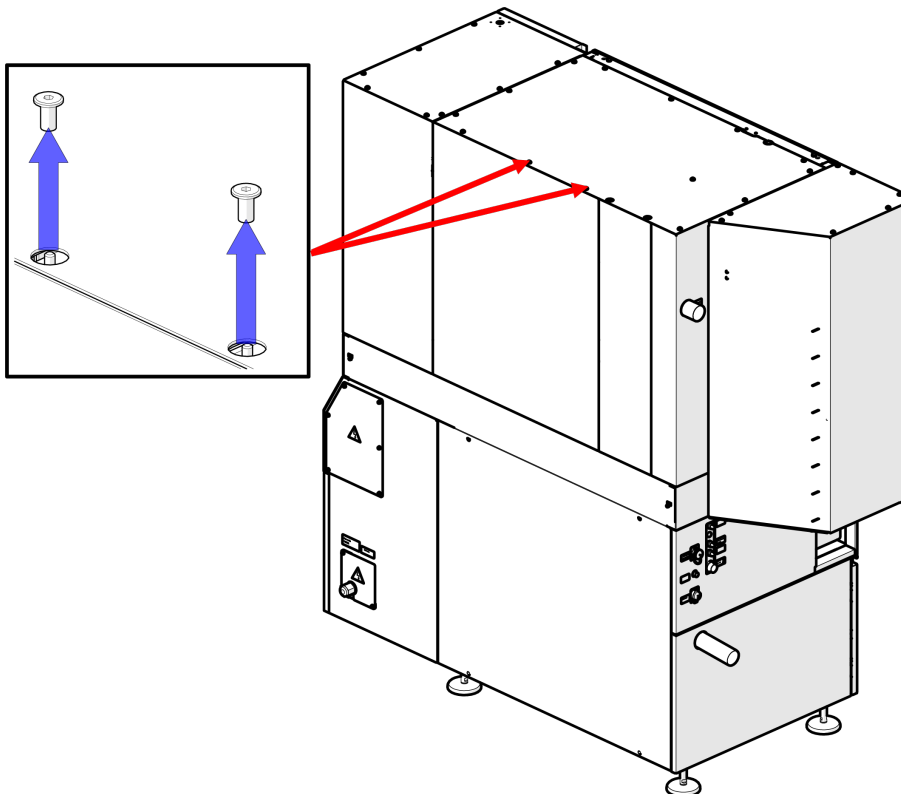

# 8 Power supply



**ELECTRICAL HAZARD**

The machine must be earthed (grounded).  
 Make sure that the actual electrical power supply voltage corresponds to the voltage stated on the type plate of the machine.  
 Incorrect voltage can damage the electrical circuit.



**ELECTRICAL HAZARD**

The equipment is protected by a safety insulation transformer.  
 Make sure that the adequate ik\_min level is present.  
 Contact a qualified electrician to verify the solution.  
 Always follow local regulations.



**ELECTRICAL HAZARD**

Disconnect the electrical power supply before installing electrical equipment.  
 Make sure that the actual electrical power supply voltage corresponds to the voltage stated on the type plate of the machine.  
 Incorrect voltage can damage the electrical circuit.



**WARNING**

In case of fire, alert bystanders, the fire brigade and cut power. Use a powder fire extinguisher. Do not use water.

We recommend a maximum cable size of 10 mm<sup>2</sup>/AWG 6. Local standards can override the recommendations for the main electrical power supply cable. Always contact a qualified electrician to verify which option is suitable for the local installation setup.

The machine is delivered without a power supply cable.

**Recommended fuse**

The machine is internally fused with **CC20A** in the input stage. The fuse is for short circuit protection only.

Voltage/frequency: 3 x 200-240 V/50-60 Hz	
Min. fuse:	16 A
Max. fuse:	40 A

Voltage/frequency: 3 x 380-480 V/50-60 Hz	
Min. fuse:	16 A
Max. fuse:	40 A

**Electrical data**

Voltage/frequency: 3 x 200-240 V/50-60 Hz	
Power consumption	200-240 V: 2.2 kW
Output, main motor	200-240 V: 1.36 kW
Max. load	200-240 V: 15 A

Voltage/frequency: 3 x 380-480 V/50-60 Hz	
Power consumption	380-480 V/50-60 Hz: 2.2 kW kW
Output, main motor	380-480 V/50-60 Hz: 1.36 kW
Max. load	380-480 V/50-60 Hz: 8 A

For specifications, see the section Technical data in the Instruction Manual.

**Install the electrical power supply**

To install the electrical power supply, the following is needed:

- Electrical power supply cable according to local regulations

Connect the cable to the electrical connection box:

1. Open the the connection box.
2. Connect as shown in the table and the illustration below.

L1	Phase
L2	Phase
L3	Phase
N	Not internally connected
PE	Earth (ground)

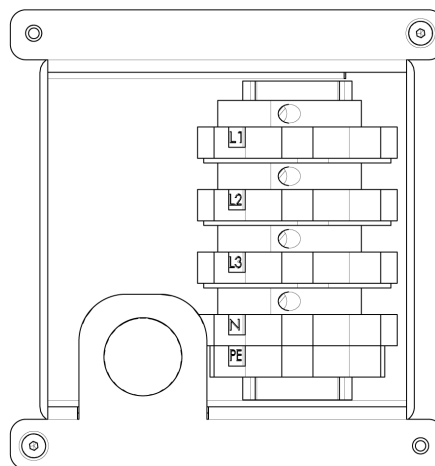
**Note**

Local standards can override the recommendations for the main electrical power supply cable. Always contact a qualified electrician to verify which option is suitable for the local installation setup.

### Equipotential bonding

Two connection points are provided for equipotential bonding of connected equipment.

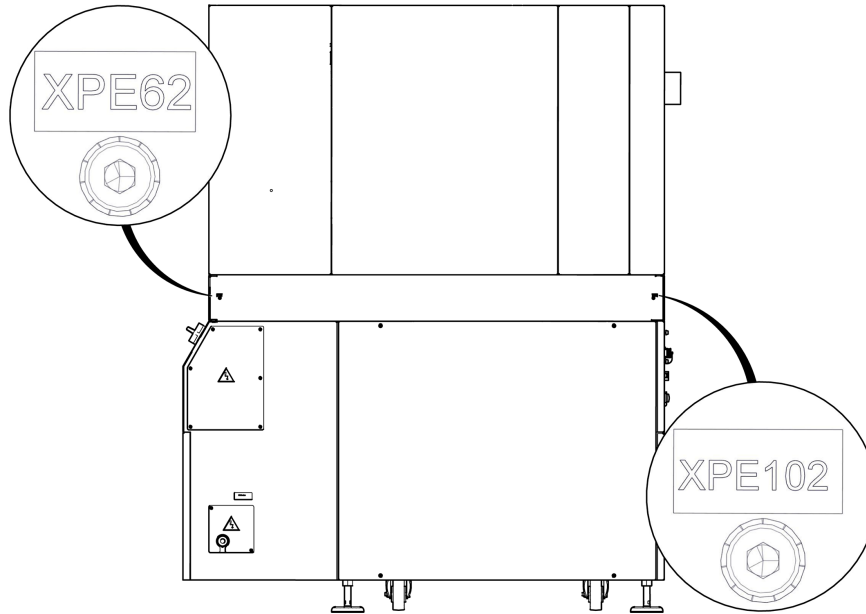

**Note**

**XPE62, and XPE102:** Equipotential bonding according to EN60204, paragraph 8.1.

### External short circuit protection

The machine must always be protected by external fuses. See the electrical table for details on the fuse size required.

The machine is equipped with an isolation transformer in the power input.

### Residual Current Circuit Breaker (RCCB)



**CAUTION**

The machine has no more than 6 mA residual current.  
The machine is equipped with an isolation transformer in the power input.  
Note that a high in-coupling current can occur when you switch on the machine.

## 9 Safety Related Parts of the Control System (SRP/CS)



**WARNING**

The machine and its parts have been designed to operate 16 hours daily/220 days annually. If used as indicated, the safety critical components must be replaced after a maximum lifetime of 20 years.  
If you use the machine for longer periods of time than indicated, the safety critical Contact Struers Service.



**Note**

SRP/CS (safety-related parts of a control system) are parts that have an influence on safe operation of the machine.

**Note**

Replacement of safety critical components must only be performed by a Struers engineer or a qualified technician (electromechanical, electronic, mechanical, pneumatic, etc.).  
Safety critical components must only be replaced by components with at least the same safety level.  
Contact Struers Service.

**Parts**

Safety related part	Manufacturer/Manufacturer description	Manufacturer catalog no.	Electrical ref.	Struers catalog no.	ID
Emergency stop	Omron	A22NE-M-N	S02	2SA41700	SF-1
Limited speed function, specimen holder mover	Schneider Electric Inverter	ATV320U15N4B	Q02	2PU23415	SF-4
Main safety cover interlock, hazardous movements	Sick Inductive sensor Schmersal Safety lock	IME2S12-04B4DW2 AZM 161SK-1212RKED-024	B44 F31	2SS00812 2SS00120	SF-5
Main safety cover interlock, water and ethanol	Sick Inductive sensor Schmersal Safety lock	IME2S12-04B4DW2 AZM 161SK-1212RKED-024	B44 F31	2SS00812 2SS00120	SF-5A
Main safety cover interlock with locking device	Schmersal Safety lock	AZM 161SK-1212RKED-024	F31	2SS00120	SF-6
MD-changer door locking device	Sick Inductive sensor	IME2S12-04B4DW2	B43	2SS00812	SF-7
MD-changer door locking device	Schmersal Safety lock	AZM 161SK-1212K-024	F30	2SS00124	SF-8
Vertical conveyor doors interlock	Sick Safety light sender/receiver SH feeder	L41S-11MA1A L41E-11MA1A	B40 B41	2HQ00110 2HQ00120	SF-9
Recirculation doors interlocks, MD	Sick Inductive sensor	IME2S12-04B4DW2	B38	2SS00812	SF-10
Alcohol exhaust timer	Beckhoff Automation	EP1957-0022	F21	2KS01957	SF-12
Specimen holder inverter	Schneider Electric Altivar 320	ATV320U15N4B	Q2	2PU23415	SF-1, SF-4, SF-5
MD module	Schneider Electric Altivar 320	ATV320U15N4B	Q3	2PU23415	SF-1, SF-5
Recirculation inverter, MD	Schneider Electric Altivar 320	ATV320U04N4B	Q5	2PU23404	SF-1, SF-5A, SF-10
Stepper motor, arm motor	Stepper motor, JVL, w. STO, 24V	MIS232S1P6H4S6	M06	2MI10231	SF-1, SF-5, SF-9
Stepper motor, MD elevator motor	Stepper motor, JVL, w. STO, 24V	MIS232S1P6H4S6	M07	2MI10231	SF-1, SF-5, SF-9

Safety related part	Manufacturer/Manufacturer description	Manufacturer catalog no.	Electrical ref.	Struers catalog no.	ID
Stepper motor, arm motor	Stepper motor, JVL, w. STO, 24V	MIS232S1P6H4S6	M08	2MI10231	SF-1, SF-5, SF-7
Stepper motor, MD elevator motor	Stepper motor, JVL, w. STO, 24V	MIS232S1P6H4S6	M09	2MI10231	SF-1, SF-5, SF-7
Stepper motor, doser arm	Stepper motor, JVL, w. STO, 24V	MIS232S1P6H4S6	M12	2MI10231	SF-1, SF-5
Stepper motor, gantry	Stepper motor, JVL, w. STO, 24V	MIS232S1P6H4S6	M13	2MI10231	SF-1, SF-5
Contactora	Omron	J7KNA-AR-22-24D	K43	2KM70909	SF-1, SF-5

# 10 Water supply

## Water inlet

The machine is supplied with a 2 m (6.6') pressure hose with GEKA coupling to connect the machine to the water supply.

Water supply - Specifications	
<b>Water pressure</b>	2-9.9 bar (29-146 psi)
<b>Water flow</b>	Min. 10 L/min. (2.6 gpm)
<b>Connection</b>	Diameter: 3/4".
<b>Tube connection</b>	Reinforced PVC hose

## Water outlet - drain

1. Connect a standard HT water outlet pipe or hose (Diameter: 50 mm (2")) to the water outlet on the left side of the machine.



**Note**  
The distance to the drain must not exceed 6000 mm (19.7'), and there must be at least 8% slope.

## 11 Compressed air

Specifications	
Pressure	6-9.9 bar (87-143 psi)
Air consumption, approx.	Max. 145 L/min (38.3 gpm) at atmospheric pressure
Air quality	The air quality is obtained via the internal regulator with built-in filter and water separator.

## 12 Exhaust

### Required



#### WARNING

An exhaust system with monitoring is required.

### Recommended

Minimum capacity: 250 m<sup>3</sup>/h (8829 ft<sup>3</sup>/h) at 100 mm (4") diameter.

## 13 Recirculation unit - (option)

If necessary, the machine can be equipped with a recirculation unit for the MD grinding/polishing station.

Struers recommends adding a Struers anti-corrosion additive to the cooling water.

The use of Struers consumables is recommended.

Other products may contain aggressive solvents, which dissolve e.g. rubber seals. The warranty may not cover damaged machine parts (e.g. seals and tubes), where the damage can be directly related to the use of consumables not supplied by Struers.

## 14 Network connection

The machine cannot use wireless networks (Wi-Fi/Bluetooth).

The machine is equipped with an RJ45 connector that can be used for remote service. Inside the machine, the RJ45 connector is connected to a Teltonika RUTX08 router (Linux operating system) which manages the firewall and VPN connections.

All ingoing connections through LAN on any ports are rejected by the firewall.

### **Remote service through VPN**

The router is pre-configured by Struers, and it requires access to the Internet if remote service is needed. Remote service can be used for software updates and troubleshooting.

Struers can provide MAC address for the specific router.

The encrypted VPN connection can give the technician from Struers Service remote access to the user interface and the database on the machine.



en For translations see  
bg За преводи вижте  
cs Překlady viz  
da Se oversættelser på  
de Übersetzungen finden Sie unter  
el Για μεταφράσεις, ανατρέξτε στη διεύθυνση  
es Para ver las traducciones consulte  
et Tõlked leiate aadressilt  
fi Katso käännökset osoitteesta  
fr Pour les traductions, voir  
hr Za prijevode idite na  
hu A fordítások itt érhetők el  
it Per le traduzioni consultare  
ja 翻訳については、  
lt Vertimai patalpinti  
lv Tulkojumus skatīt  
nl Voor vertalingen zie  
no For oversættelser se  
pl Aby znaleźć tłumaczenia, sprawdź  
pt Consulte as traduções disponíveis em  
ro Pentru traduceri, consultați  
se För översättningar besök  
sk Preklady sú dostupné na stránke  
sl Za prevode si oglejte  
tr Çeviriler için bkz  
zh 翻译见

[www.struers.com/Library](http://www.struers.com/Library)