

TegraSystem Remote

Instruction Manual

Original Instructions



CE

Doc. no.: 16967025_B_en
Date of release: 2023.12.22

Copyright

The contents of this manual are the property of Struers ApS. Reproduction of any part of this manual without the written permission of Struers ApS is not allowed.

All rights reserved. © Struers ApS.

Table of Contents

1 About this manual	6
1.1 Accessories and consumables	6
2 Safety	6
2.1 Intended use	6
2.2 TegraSystem Remote safety precautions	7
2.2.1 Read carefully before use	7
2.3 Safety messages	8
2.4 Safety messages in this manual	9
3 Get started	10
3.1 Device description	10
3.2 Overview	11
3.2.1 Control box	12
3.2.2 Air control unit	13
4 Transport and storage	13
4.1 Storage	13
4.2 Transport	13
5 Installation	14
5.1 Unpack the machine	14
5.2 Check the packing list	14
5.3 Location	15
5.4 Installation - Specimen mover	16
5.4.1 Mounting a preparation disc	17
5.4.2 Insert a specimen mover plate	19
5.4.3 Connecting the specimen mover	19
5.4.4 Removing the specimen mover	21
5.5 Power supply	22
5.5.1 Single-phase supply	23
5.5.2 2-phase supply	23
5.5.3 Powering the control box	23
5.5.4 Connecting the equipment	24
5.6 Waste outlet	24
5.7 Noise	24
5.8 Vibration	25

6	Prepare the device	25
6.1	Control panel functions	25
6.2	The display	26
6.2.1	Main menu	26
6.3	Change the settings	27
7	Operate the device	27
7.1	Start-up - the first time	27
7.2	28
7.2.1	General configuration	28
7.2.2	Machine Configuration	29
7.3	Settings - Preparation	30
7.3.1	Recommendations for grinding	31
7.4	Starting and stopping the preparation process	31
7.5	Settings - Manual preparation	32
7.6	Manual preparation	32
8	TegraDoser Remote (option)	33
8.1	Installation	35
8.1.1	Unpack the machine	35
8.1.2	Check the packing list	35
8.1.3	Location	36
8.1.4	Powering TegraDoser Remote	36
8.1.5	Installing TegraDoser Remote	36
8.1.6	Mounting tubes on doser bottles	37
8.1.7	Changing lubricant/suspension	37
8.2	Operating TegraDoser Remote	38
8.2.1	Control panel functions	38
8.2.2	The display	38
8.2.3	Main menu	40
8.2.4	Changing settings and text	40
8.2.5	Setting up the preparation process	41
8.2.6	Settings - TegraDoser Remote	42
8.3	Configuration	43
8.3.1	Bottle configuration	44
8.3.2	Configuring a user surface	45
8.3.3	Configuring a user suspension	46
8.3.4	Configuring a user lubricant	46
8.3.5	The Options screen	47
8.3.6	Configuring operation mode	48
8.3.7	New pass code	48

8.4	Preparation methods	49
8.4.1	Method groups	50
8.4.2	Selecting a method	51
8.4.3	Copying a preparation method	51
8.4.4	Creating a preparation method	52
8.4.5	Moving a method	54
8.4.6	Deleting a method	54
8.4.7	Editing a method	54
8.4.8	Creating a method step	55
8.4.9	Editing user method steps	56
8.4.10	Deleting a user method step	58
8.4.11	Defining surfaces, lubricants and suspensions	59
8.4.12	Setting dosing levels	60
8.5	The preparation process	62
8.5.1	Starting and stopping the preparation process	62
8.5.2	Changing settings during preparation	62
9	Maintenance and service	63
9.1	General cleaning	63
9.2	Change the tubes	64
9.3	Daily	65
9.4	Weekly	65
9.5	Monthly	66
9.5.1	Empty the water/oil filter	66
10	Spare parts	67
11	Disposal	67
12	Troubleshooting	67
12.1	Troubleshooting	67
12.2	Errors	69
13	Technical data	71
13.1	Technical data sheet	71
13.2	Noise and vibration levels	73
13.3	Diagrams	74
13.4	Legal and regulatory information	77
14	Manufacturer	77
	Declaration of Conformity	79

1 About this manual

**CAUTION**

Struers equipment must only be used in connection with and as described in the Instruction Manual supplied with the equipment.

**Note**

Read the Instruction Manual carefully before use.

**Note**

If you want to view specific information in detail, see the online version of this manual.

1.1 Accessories and consumables

Accessories

For information about the available range, see the TegraSystem Remote brochure:

- [The Struers Website](http://www.struers.com) (<http://www.struers.com>)

Consumables

The equipment is designed to be used only with Struers consumables specifically designed for this purpose and this type of machine.

Other products may contain aggressive solvents, which dissolve e.g. rubber seals. The warranty may not cover damaged machine parts (e.g. seals and tubes), where the damage can be directly related to the use of consumables not supplied by Struers.

For information about the available range, see: [The Struers Website](http://www.struers.com) (<http://www.struers.com>).

2 Safety

2.1 Intended use

For professional automatic materialographic preparation (grinding and polishing) of materials for materialographic inspection in a closed secured location without access for employees only to be operated by skilled/trained personnel using manipulators.

The equipment is designed to be used only with Struers consumables specifically designed for this purpose and this type of machine.

The machine is for use in a professional working environment (e.g. a materialographic laboratory with a closed secured area).

TegraSystem Remote is intended to be used in combination with:

- TegraDoser Remote

Do not use the machine for the following

Preparation (grinding or polishing) of materials other than solid materials suitable for materialographic studies.

The machine must not be used for any type of explosive and/or flammable material, or materials which are not stable during machining, heating or pressure.

Model

TegraSystem Remote

2.2 TegraSystem Remote safety precautions

2.2.1 Read carefully before use

In combination with: TegraDoser Remote.

Ignoring this information and mishandling of the equipment can lead to severe bodily injuries and material damage.

Specific safety precautions - residual risks

1. The operator must read the Instruction Manual and, where applicable, the Safety Data Sheets for the applied consumables.
2. The machine must be placed on a safe and stable table with an adequate working height. The table must be able to carry at least the weight of the machine and the accessories.
3. Prolonged exposure to loud noises may cause permanent damage to a person's hearing. Use hearing protection if the exposure to noise exceeds the levels set by local regulations.
4. The machine must be disconnected from the electrical power supply before any service. Wait 5 minutes until residual potential on the capacitors is discharged.
5. The machine must not be used for any type of explosive and/or flammable material, or materials which are not stable during machining, heating or pressure.

General safety precautions

1. The machine must be installed in compliance with local safety regulations. All functions on the machine and any connected equipment must be in working order.
2. The operator must read the safety precautions and Instruction Manual, as well as relevant sections of the manuals for any connected equipment and accessories.
3. This machine must be operated and maintained only by skilled/trained personnel.
4. Make sure that the actual electrical power supply voltage corresponds to the voltage stated on the type plate of the machine. The machine must be earthed (grounded). Always follow

- local regulations. Always switch off the electrical power supply and remove the plug or power cable before dismantling the machine or installing additional components.
5. Consumables: only use consumables specifically developed for use with this type of materialographic machine. Alcohol-based consumables: follow the current safety rules for handling, mixing, filling, emptying, and disposing of alcohol-based liquids.
 6. If you observe malfunctions or hear unusual noises, switch off the machine and call technical service.
 7. Do not switch the machine on and off more than once every five minutes. Damage to the electrical components could occur.
 8. In case of fire, alert bystanders and the fire brigade. Disconnect the electrical power supply. Use a powder fire extinguisher. Do not use water.
 9. Struers equipment must only be used in connection with and as described in the Instruction Manual supplied with the equipment.
 10. The equipment is designed to be used only with Struers consumables specifically designed for this purpose and this type of machine.
 11. If the equipment is subjected to misuse, incorrect installation, alteration, neglect, accident or incorrect repair, Struers will accept no responsibility for damage to the user or the equipment.
 12. Dismantling of any part of the equipment, during service or repair, should always be performed by a qualified technician (electromechanical, electronic, mechanical, pneumatic, etc.).

2.3 Safety messages

Struers uses the following signs to indicate potential hazards.



ELECTRICAL HAZARD

This sign indicates an electrical hazard which, if not avoided, will result in death or serious injury.



DANGER

This sign indicates a hazard with a high level of risk which, if not avoided, will result in death or serious injury.



WARNING

This sign indicates a hazard with a medium level of risk which, if not avoided, could result in death or serious injury.



CAUTION

This sign indicates a hazard with a low level of risk which, if not avoided, could result in minor or moderate injury.



CRUSHING HAZARD

This sign indicates a crushing hazard which, if not avoided, could result in minor, moderate or serious injury.

**HEAT HAZARD**

This sign indicates a heat hazard which, if not avoided, can result in minor, moderate or serious injury.

**Emergency stop**

Emergency stop

General messages**Note**

This sign indicates that there is a risk of damage to property, or a need to proceed with special care.

**Hint**

This sign indicates that additional information and hints are available.

2.4 Safety messages in this manual**CAUTION**

Do not lift the whole unit only by the lifting eye mounted on the specimen mover.

**CAUTION**

Struers equipment must only be used in connection with and as described in the Instruction Manual supplied with the equipment.

**ELECTRICAL HAZARD**

Switch off the electrical power supply before installing electrical equipment.

The machine must be earthed (grounded).

Make sure that the actual electrical power supply voltage corresponds to the voltage stated on the type plate of the machine.

Incorrect voltage can damage the electrical circuit.

**CAUTION**

If the air control unit is located outside the enclosed area, the exhaust air must be led back inside the enclosed area.

**WARNING**

Switch off the machine, disconnect the electrical power cable and wait 5 minutes before you dismantle the machine or install additional components.

**ELECTRICAL HAZARD**

Switch off the electrical power supply before installing electrical equipment.

The machine must be earthed (grounded).

Make sure that the actual electrical power supply voltage corresponds to the Incorrect voltage can damage the electrical circuit.



CAUTION

Prolonged exposure to loud noises may cause permanent damage to a person's hearing.
Use hearing protection if the exposure to noise exceeds the levels set by local regulations.



CAUTION

Do not use the machine with non-compatible accessories or consumables.



CRUSHING HAZARD

Take care of your fingers when handling the machine.
Wear safety shoes when handling heavy machinery.

3 Get started

3.1 Device description

TegraSystem Remote is a semi automatic grinding and polishing machine for 200 mm diameter preparation disc and must be operated by manipulators. It is divided in three parts connected by cables.

Part I, the preparation part, must be placed in a closed secured location without access for employees and must be operated by manipulators.

Part II, the air control box, can either be placed in the enclosed area or outside.

Part III, the control box, must be placed next to the operator outside the closed secured location.

The preparation process starts by the operator selecting the grinding/polishing surface and the cooling fluid/abrasive suspension to be applied. The fluids are applied manually or by a separate dosing unit.

The operator places the specimens in the specimen mover plate and the splash guard using manipulators.

The operator sets the process parameters (i.e. disc rotation speed, time, specimen force and mover head rotation speed) before starting the process.

The operator starts the process by pressing the Start button on the control box.

Cooling fluid/abrasive suspensions are applied either by a dosing unit or manually using manipulators.

The machine stops after the selected time or by the operator presses the Stop button on the control box.

The operator removes and cleans the specimens using manipulators before the next preparation step or inspection.

3.2 Overview

TegraSystem Remote

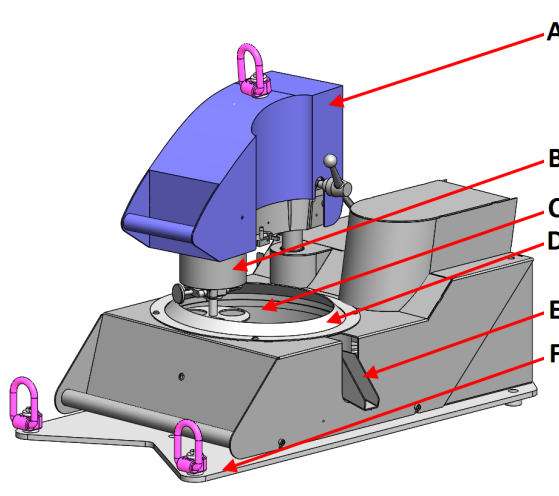

Front view

- A Specimen mover
- B Specimen mover head
- C Turntable
- D Splash guard
- E Waste outlet
- F Lifting platform

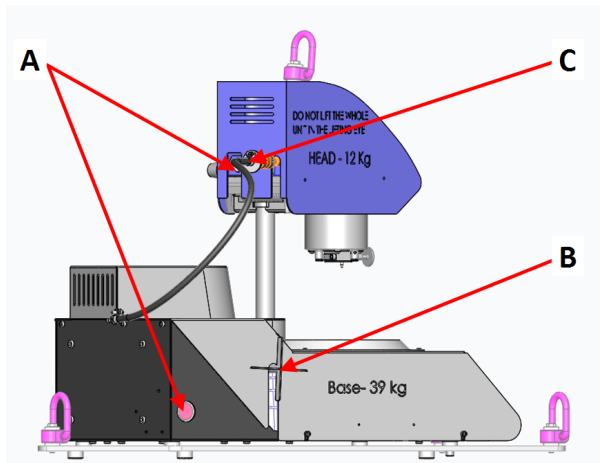

Side view

- A Connection - Air control unit
- B Spider screw for securing the specimen mover
- C Connection - Air supply

Specimen mover

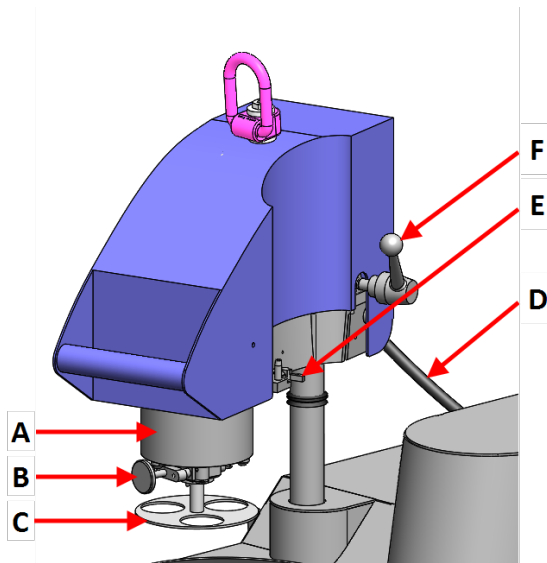

Front view

- A Specimen mover head
- B Push release button for specimen mover plate
- C Specimen mover plate
- D Connection - Air control unit
- E Connection - Doser head, TegraDoser Remote
- F Handle for unlocking the specimen mover

3.2.1 Control box

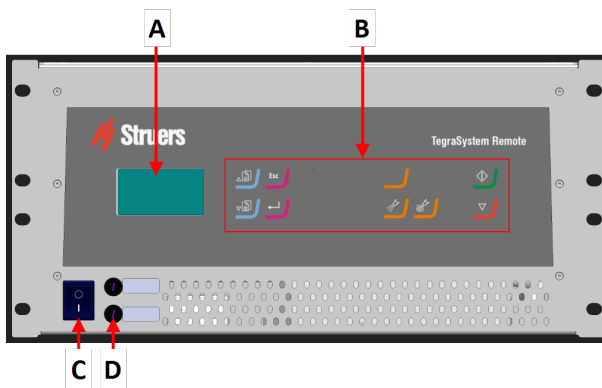

Front view

- A Display
- B Control panel
- C Main switch
- D Fuses

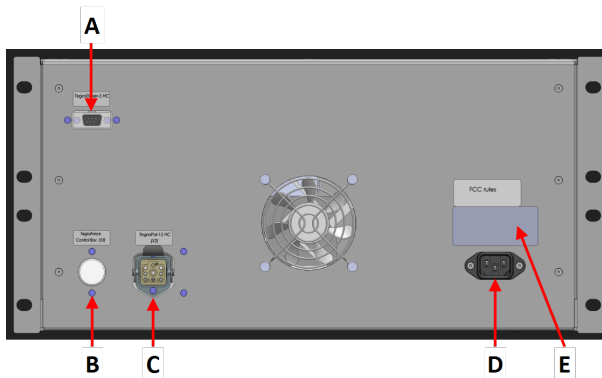

Rear view

- A Connection - TegraDoser Remote
- B Connection - Specimen mover
- C Connection - Polishing unit
- D Power socket
- E Type plate

3.2.2 Air control unit

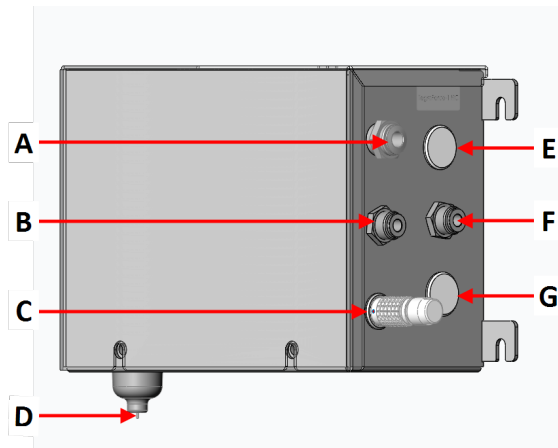

- A** Compressed air inlet
- B** Air supply - Specimen mover
- C** Dummy plug. Used when TegraDoser Remote is connected
- D** Release outlet valve
- E** Connection - Control box
- F** Exhaust air outlet
- G** Connection - Specimen mover

4 Transport and storage

If, at any time after the installation, you have to move the unit or place it in storage, there is a number of guidelines we recommend that you follow.

- Package the unit securely before transportation. Insufficient packaging could cause damage to the unit and will void the warranty. Contact Struers Service.
- We recommend that you use the original packaging and fittings.

4.1 Storage



Note

We recommend that you keep all original packaging and fittings for future use.

- Disconnect the unit from the electrical power supply.
- Remove any accessories.
- Clean and dry the unit before storage.
- Place the machine and accessories in their original packaging.

4.2 Transport



Note

We recommend that you keep all original packaging and fittings for future use.

To transport the machine safely, follow these instructions.

Preparing for transport

1. Disconnect the unit from the electrical power supply.
2. Disconnect the compressed air supply.
3. If connected, disconnect the dosing head.
4. Remove any accessories.
5. Clean and dry the unit.

Moving the machine



CAUTION

Do not lift the whole unit only by the lifting eye mounted on the specimen mover.

1. Connect the lifting straps to the lifting eyes at all points on the lifting platform.
2. Make sure that the tension on the lifting straps connected to the lifting eyes is distributed evenly.
3. Lift the unit by the lifting eyes on the unit.

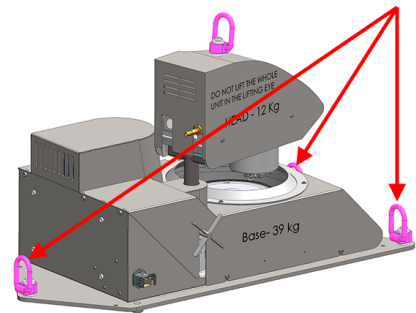

5 Installation

5.1 Unpack the machine



Note

We recommend that you keep all original packaging and fittings for future use.

1. Carefully open and remove the sides and the top of the box.
2. Remove the loose parts.
3. Remove the units from the pallet.

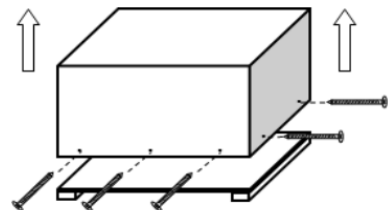

5.2 Check the packing list

The equipment is delivered in several boxes:

- Polishing unit
- Specimen mover
- Control box
- Air control unit

Optional accessories may be included in the packing box.

The packing box contains the following items:

Pcs.	Description
1	Polishing unit
1	Specimen mover
1	Control box
1	Air control unit
1	Pressure hose. Diameter: ¼". Length: 3 m
3	Washer. Diameter: 16.5 x 29.5 x 1 mm
2	Washer. Diameter: 16.5 x 29.5 x 3 mm
1	Air inlet tube with quick coupling, Diameter: 8 mm. Length: 8 m
1	Splash guard
2	Electrical power supply cables
3	Communication cable: <ul style="list-style-type: none"> • Polishing unit - Control box • Specimen mover - Air control unit • Control box - Air control unit
1	Instruction Manual set

5.3 Location

- Make sure that the following facilities are available:
 - Power supply (outside the enclosed area)
 - Compressed air supply (inside the enclosed area)

Polishing unit

- Place the machine on a level and stable surface inside the enclosed area.

Specimen mover

Mount the specimen mover on the polishing unit before placing the polishing unit in the enclosed area.

Control box

- Place the control box close to the power supply.

- Place the control box on a stable surface, or mount it in a rack system outside the enclosed area.

Air control unit

- Place the air control unit either inside or outside the enclosed area.

TegraDoser Remote (option)

- Place the device on a level and stable surface outside the enclosed area.

5.4 Installation - Specimen mover

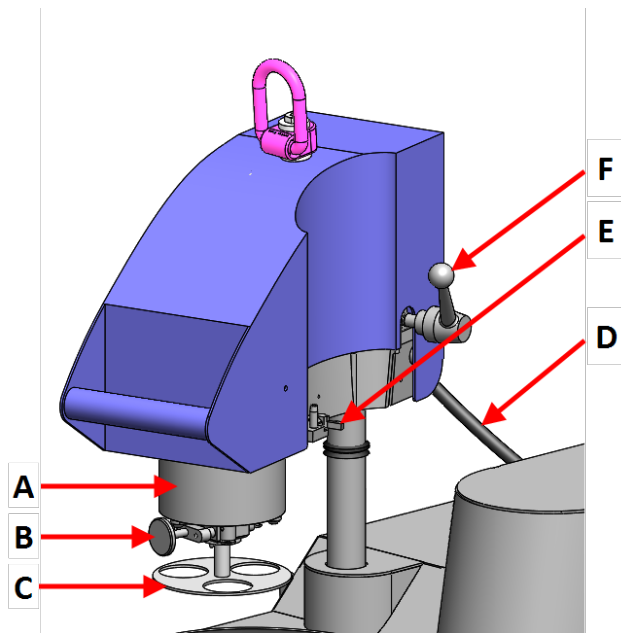

- A** Specimen mover head
- B** Push release button for specimen mover plate
- C** Specimen mover plate
- D** Connection - Air control unit
- E** Connection - Doser head, TegraDoser Remote
- F** Handle for unlocking the specimen mover



Note

This device must be mounted securely on the machine.

Procedure

1. Guide the column down into the connection hole. (A)

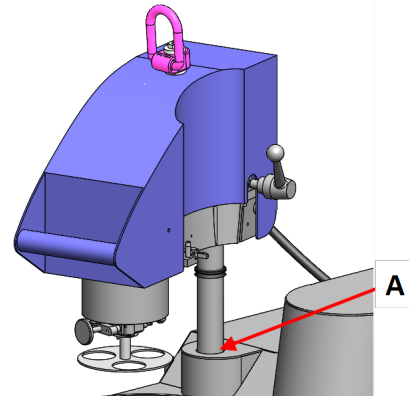
**A** Connection hole

2. Adjust the distance between the preparation disc and the specimen mover plate:
 - Mount a preparation disc on the machine. See [Mounting a preparation disc ▶ 17](#).
 - Insert a specimen mover plate on the specimen mover. See [Insert a specimen mover plate ▶ 19](#).
 - Use the washers supplied to raise the specimen mover until the space between the preparation disc and the specimen mover plate is approx. 1 - 1.5 mm.
3. Tighten the spider screw. (A)
Do not tighten the spider screw completely.

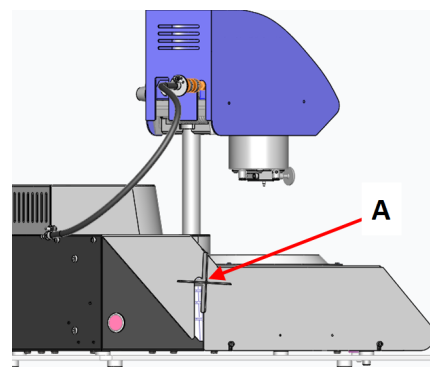
**A** Spider screw**5.4.1 Mounting a preparation disc****Note**

Make sure that the preparation disc is clean and has no debris that prevents it from lying flat on the turntable.

Procedure

1. Place the preparation disc on the turntable.
2. Rotate it until the pins on the underside of the disc engage with the corresponding holes in the turntable.
3. Insert the mover plate. See [Insert a specimen mover plate ▶ 19](#).
4. Before you tighten the spider screw, check the margin between the hole of the specimen mover plate and the edge of the preparation disc.

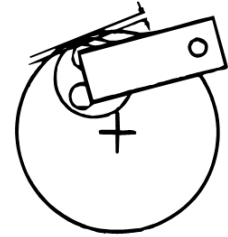

Diameter of the holes	Disc margin extending beyond the preparation disc
40 mm	1.5 mm
1½"	2.5 mm
1¼"	6.0 mm
30 mm	6.5 mm
25 mm	9.0 mm

5. When you have adjusted the disc position, tighten the spider screw firmly.
The specimen mover will now remain in position.
6. Make sure that the distance between the preparation disc and the specimen mover plate is correct. The column must remain in position.
7. Tighten the spider screw. (A)

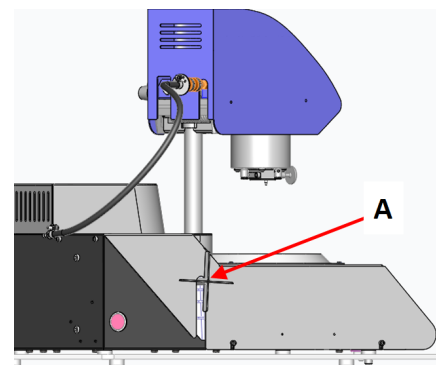

Preparation disc types

The machine can be used with the following disc types:

Preparation disc types	Preparation surface
MD-Disc	For MD consumable.
Wet grinding disc	For SiC Paper.
Aluminum disc	For adhesive-backed consumable.

5.4.2 Insert a specimen mover plate

The specimen mover must be used with specimen mover plates for single specimens.

- Press the specimen mover plate into the specimen mover head until the pin of the push release button is in place.

5.4.3 Connecting the specimen mover



ELECTRICAL HAZARD

Switch off the electrical power supply before installing electrical equipment. The machine must be earthed (grounded). Make sure that the actual electrical power supply voltage corresponds to the voltage stated on the type plate of the machine. Incorrect voltage can damage the electrical circuit.

The specimen mover is connected to the air control unit.

The air control unit provides the power supply (24 V) to the specimen mover.

Electrical power connection

See [Connecting the equipment ► 24](#).

Compressed air

The air control unit provides compressed air to the specimen mover. Compressed air is released from the air control unit when the specimen force is regulated or the force is taken off the specimens.



CAUTION

If the air control unit is located outside the enclosed area, the exhaust air must be led back inside the enclosed area.

Air quality

Recommended quality: ISO 8573-1, class 5.6.4

Air pressure

The air pressure must be between 5 bar (72 psi) and 9.9 bar (143 psi)

1. Connect the specimen mover to the air control unit.
See [Connecting the equipment ▶ 24](#).



Hint

The specimen mover requires a continuous flow of compressed air through the regulator valve – a faint hissing sound does not mean that there is an air leak.

2. Connect the pressure hose to the air inlet on the specimen mover. (A)

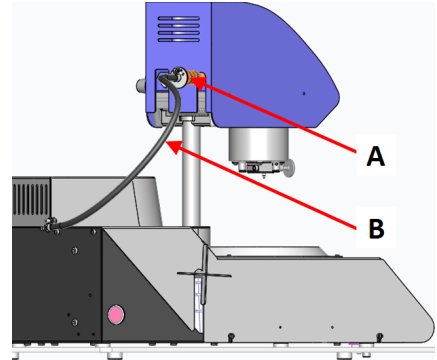

- A** Connection - Air control unit
- B** Communication cable

3. Connect the pressure hose to the air supply from the air control unit. (A)

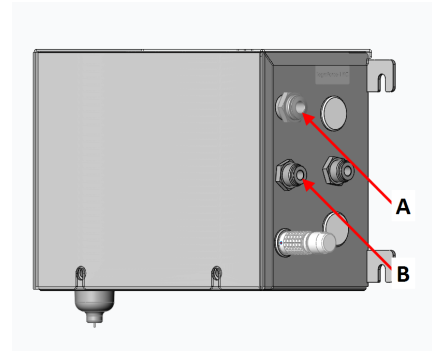

- A** Compressed air inlet
- B** Air supply - Specimen mover

4. Connect the compressed air supply to the air inlet on the air control unit. (A)

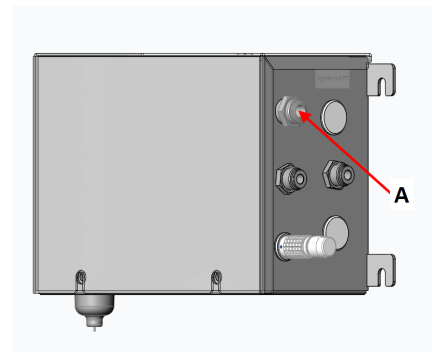

- A** Compressed air inlet

5.4.4 Removing the specimen mover

If needed, follow this procedure to remove the specimen mover.

Procedure

1. Switch off the control unit.
2. Disconnect the specimen mover from the compressed air supply. (A)
3. Disconnect the communication cable connecting the specimen mover. (B)

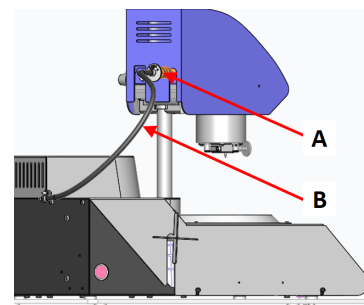

4. If needed, disconnect the TegraDoser Remote doser head from the specimen mover. (A)
5. Release the handle on the specimen mover and let the unit swing up into the upper position. (B)
6. Press the push release button and remove the specimen mover plate.

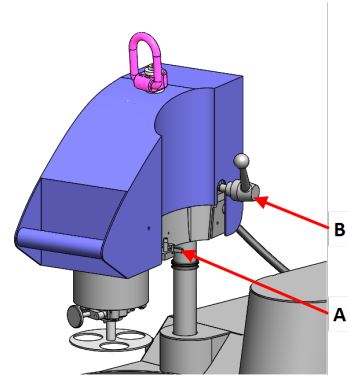

7. Remove the preparation disc.
8. Press down the specimen mover until the specimen mover head is locked in position.
9. Hold the specimen mover in position and release the spider screw. (A)
10. Lift the specimen mover straight up by the lifting eye.
11. Place the specimen mover on a safe and stable support.

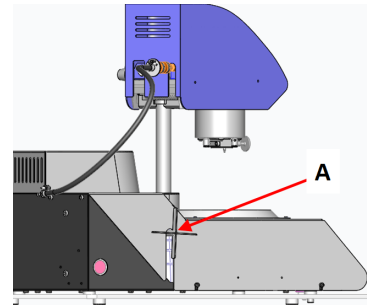

5.5 Power supply



WARNING

Switch off the machine, disconnect the electrical power cable and wait 5 minutes before you dismantle the machine or install additional components.



ELECTRICAL HAZARD

Switch off the electrical power supply before installing electrical equipment. The machine must be earthed (grounded). Make sure that the actual electrical power supply voltage corresponds to the voltage stated on the type plate of the machine. Incorrect voltage can damage the electrical circuit.



Note

An autotransformer is required in countries with a 110 V electrical power supply.

Power socket

The electrical power supply socket must be easy to access. The electrical power supply socket must be located at a height ranging from 0.6 m to 1.9 m (2½" to 6") above floor level. Not higher than 1.7 m (5' 6") is recommended.

**Note**

The equipment is shipped with 2 types of electrical power cables. If the plug supplied on these cables is not approved in your country, the plug must be replaced with an approved plug.

5.5.1 Single-phase supply

Single-phase supply

The 2-pin plug (European Schuko) is for use on single-phase electrical power connections.



The leads must be connected as follows:

Yellow/Green	Earth (ground)
Brown	Line (live)
Blue	Neutral

5.5.2 2-phase supply

The 3-pin plug (North American NEMA) is for use on 2-phase electrical power connections.

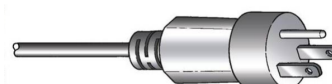

The leads must be connected as follows:

Green	Earth (ground)
Black	Line (live)
White	Line (live)

5.5.3 Powering the control box

**ELECTRICAL HAZARD**

Switch off the electrical power supply before installing electrical equipment. The machine must be earthed (grounded). Make sure that the actual electrical power supply voltage corresponds to the voltage stated on the type plate of the machine. Incorrect voltage can damage the electrical circuit.

**Note**

An autotransformer is required in countries with a 110 V electrical power supply.

The control box powers the following units:

- Polishing unit
- Air control unit
- TegraDoser Remote (option)

Electrical power supply cable

1. Connect the electrical power cable to the control box (IEC 320 connector).
2. Connect the other end of the cable to the electrical power supply socket.



5.5.4 Connecting the equipment



ELECTRICAL HAZARD

Switch off the electrical power supply before installing electrical equipment. The machine must be earthed (grounded). Make sure that the actual electrical power supply voltage corresponds to the voltage stated on the type plate of the machine. Incorrect voltage can damage the electrical circuit.

The equipment is supplied with 3 communication cables.

Polishing unit - Control box

The control box powers the polishing unit.

1. Connect the cable from the rear of the polishing unit to the control box.

Control box - Air control unit

The control box powers the air control unit through a combined electrical power supply and data communication cable (24 V).

1. Connect the cable from the control box to the air control unit.

Specimen mover - Air control unit

The air control unit powers the specimen mover.

1. Connect the cable from the specimen mover to the air control unit.

5.6 Waste outlet

1. Place a container under the waste outlet tray.
2. Dispose of the waste according to local safety regulations.

5.7 Noise

For information on the sound pressure level value, see this section: [Noise and vibration levels ▶ 73](#)



CAUTION

Prolonged exposure to loud noises may cause permanent damage to a person's hearing. Use hearing protection if the exposure to noise exceeds the levels set by local regulations.







5.8 Vibration



See [Noise and vibration levels](#) ►73.

6 Prepare the device

6.1 Control panel functions



Button	Function
	Scroll up <ul style="list-style-type: none"> Press this button to scroll up in a screen and to increase the value of a setting.
	Scroll down <ul style="list-style-type: none"> Press this button to scroll down in a screen and to decrease the value of a setting.
	Escape <p>Use this button on the control panel to return to previous functions or values.</p> <ul style="list-style-type: none"> Press the button to return to the main menu. Press the button to return to the last function or value. Press the button to cancel changes.
	Select/Enter <ul style="list-style-type: none"> Press this button to enter a field, for instance a setting, to select a value, and to confirm a selection.
	Special function <p>This button is reserved for special functions.</p>
	Lubricant <p>This function is active when a dosing unit is connected.</p> <ul style="list-style-type: none"> Manual override: Press this button to apply lubricant from the dosing unit.
	Abrasive <p>This function is active when a dosing unit is connected.</p> <ul style="list-style-type: none"> Manual override: Press this button to apply suspension from the dosing unit.

Button	Function
	Start <ul style="list-style-type: none"> Starts the preparation process.
	Stop <ul style="list-style-type: none"> Stops the preparation process.

6.2 The display

The display is the user-interface to the software.



Note
The screens shown in this manual may differ from the actual screens in the software.

When you switch on the machine, the display shows the configuration and the version of the installed software.

After start-up, the display changes to the screen last shown when the machine was switched off.

The display is divided into some main areas. See this example.

A Title bar

The title bar shows the function you have selected.

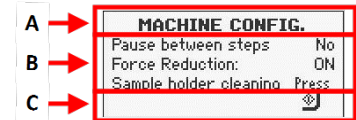

B Information fields

These fields show information about the selected function. In some fields you can select and change the value.

C Function key options

The functions shown depend on the screen that is displayed.

Navigating in the display

Use the buttons on the control panel to navigate in the display.

See [Control panel functions](#) ► 25.

Sound

Short beep

A short beep, when you press a key, indicates that the selection is confirmed.

Long beep

A long beep, when you press a button, indicates that the key cannot be activated at the moment.

6.2.1 Main menu

From the **Main menu** screen you can choose between the following options:

- Preparation.** See [Settings - Preparation](#) ► 30.

- **Manual preparation.** See [Manual preparation ▶ 32](#).
- **Configuration.** See [▶ 28](#).

6.3 Change the settings

Procedure

1. Select the setting you wish to change.
2. Confirm your selection.
 - If there are two values, toggle between the values.
 - If there are more than two values, either a pop-up box is shown or a scroll-box is shown around the value.
3. Select the setting you wish to use.



You can undo the change.

4. Confirm your selection.

7 Operate the device



CAUTION

Do not use the machine with non-compatible accessories or consumables.

If TegraDoser Remote is connected, see [Operating TegraDoser Remote ▶ 38](#).

7.1 Start-up - the first time

Setting up the preparation process

To set up the software for the preparation process, see the following sections:

- [Machine Configuration ▶ 29](#)
- [Settings - Preparation ▶ 30](#)

7.2

You can set a number of settings and parameters.

1. From the **Main menu**, select **Configuration**.
2. From the **Configuration** screen, select:
 - **General Configuration** for general settings.
 - **Machine Configuration** for setting specific parameters.

7.2.1 General configuration

You can change language and display contrast.

1. From the **Main menu** screen select **Configuration**.
2. Confirm your selection.
3. From the **Configuration** screen, select **General Configuration**.
4. Confirm your selection.

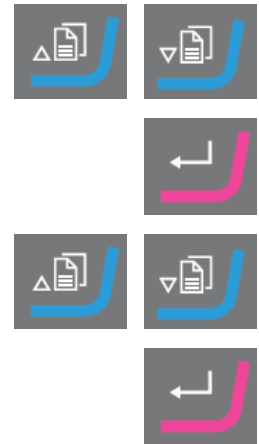

Language

1. Select **Language**.
2. Select the language you wish to use. If needed, you can change the language at a later date.
3. Confirm your selection.



Display contrast

1. Select **Display contrast**.
2. Confirm your selection.



3. Select the desired setting.
 - Default: 25
4. Confirm your selection.



Returning to the Main menu screen

1. Return to the **Main menu** screen.



7.2.2 Machine Configuration

You can set a number of settings and parameters.

1. From the **Main menu**, select **Configuration**.
2. From the **Configuration** screen, select **Machine Configuration**.

Settings	Description
Pause between steps	<p>This function can only be used when TegraDoser Remote is connected.</p> <p>When two preparation steps following each other are based on the same surface, and suspension and lubricant, these two steps are joined so that the preparation continues directly from one step to the next. The force and dosing level can be changed from one step to the next, and you do not have to restart the machine.</p> <p>You can stop the machine if you are using two steps for SiC with the same grit size. If needed, toggle to select Yes.</p>
Single sample cleaning	<ol style="list-style-type: none"> 1. Select Yes to press down the pressure feet. 2. Clean the pressure feet. 3. When you are done, select Single sample cleaning to move the pressure feet up.
Force system	Toggle between Air (for compressed air) and Man. (for functions other than compressed air).

7.3 Settings - Preparation

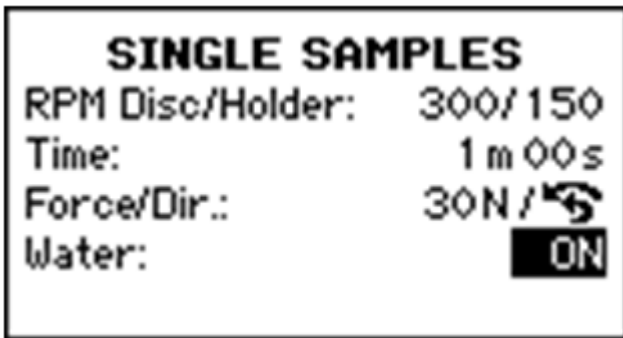

1. From the **Main menu** screen, select **Preparation**.
2. Confirm your selection.
3. Select the preparation settings you wish to use.



See also [Recommendations for grinding](#) ► 31.

Settings	
RPM Disc/Mover plate	
Disc	40 - 600. In increments of 10.
Mover plate	50 - 150. In increments of 10.
Time	From 5 s to 1 min. In steps of 5 s.
	From 1 min to 5 min. In steps of 10 s.
	From 5 min to 60 min. In steps of 30 s.
Force/Dir.	10-50 N in steps of 5 N.
	Clockwise or Counter-clockwise

4. Place the specimens in the specimen mover plate.
5. You can start the preparation process.

Recommended preparation disc speeds

Before you can start the preparation process, you must select the disc speed.

1. From the **Main menu** screen select **Preparation**.
2. Confirm your selection.



3. Select the preparation type you wish to use.



Settings	Speed
Grinding	300 rpm
Polishing	150 rpm
User def.	40 - 600 rpm

4. Confirm your selection.



7.3.1 Recommendations for grinding

If grinding with coarse abrasive is necessary, see the following guidelines for improving the planeness.

- Make sure that the distance between specimen mover plate and preparation disc is maximum 1 - 1.5 mm.
- Make sure that the height of the specimen is between 8 – 28 mm and does not exceed 0.7 x the diameter of the specimen.
Example: a specimen with a diameter of 30 mm should not be higher than $30 \times 0.7 = 21$ mm.
- Use a grain size as small as possible.
- Use a mounting resin with a wear resistance similar to the wear resistance of the specimens.
- Use 150 rpm speed for both the grinding disc and the specimen mover. If you use lower speeds, decrease the speed on both the disc and the specimen mover.
- Use low force.

7.4 Starting and stopping the preparation process

Start the machine

1. Select the desired preparation settings.
2. Make sure that the grinding or polishing surface is correctly mounted.
3. Make sure that the driving pins on the preparation disc engage with the holes in the turntable.
4. Insert the specimens in the specimen mover plate.
5. Press the Start button on the control panel to start the preparation.
The disc and the specimen mover plate start turning at the pre-set speed.
The pressure feet move down.
6. Apply water, suspension and/or lubricant manually.



Stopping the machine

The machine stops automatically when the preset preparation time has expired.

Alternatively, you can stop the machine:

- Press the **Stop** button.
- Clean the specimen mover plate and the specimens before you continue with the next preparation step or inspection.



7.5 Settings - Manual preparation

Before you start the preparation process, select the preparation surface and the disc speed.

Procedure

1. From the **Main menu** screen, select **Manual preparation**.
2. Press **Enter** to select the **Manual preparation** screen.
3. Select the preparation method you wish to use.



Possible selections:

- **Grinding**
- **Polishing**
- **User def.**



Methods	Speed	Water
Grinding	3000 rpm	On
Polishing	150 rpm	Off
User def.	40 - 600 rpm	On/Off

If you select **User def.**, define the settings, if needed. See [Change the settings ▶ 27](#).

4. Confirm your selection.



7.6 Manual preparation

If you cannot prepare a specimen by using a standard specimen mover plate, you can prepare it manually by using manipulators.

When you perform manual preparation, use the manipulator to hold the specimen. Press the specimen firmly onto and across the preparation surface.

**Note**

When you perform manual grinding or polishing, be careful not to touch the disc.

**Note**

Do not try to collect a specimen from the tray while the disc is rotating.

**Note**

When the disc is rotating, make sure the manipulators are kept completely clear of its periphery and out of the splash bowl.

1. From the **Main menu** screen, select **Manual preparation**.



2. Confirm your selection.



3. Select the preparation method you wish to use.



Possible selections:

- **Grinding**
- **Polishing**
- **User def.**

4. Confirm your selection.



5. Press Start.



6. When needed, press Stop.



8 TegraDoser Remote (option)

**CAUTION**

Do not use the machine with non-compatible accessories or consumables.

TegraDoser Remote connected to TegraSystem Remote

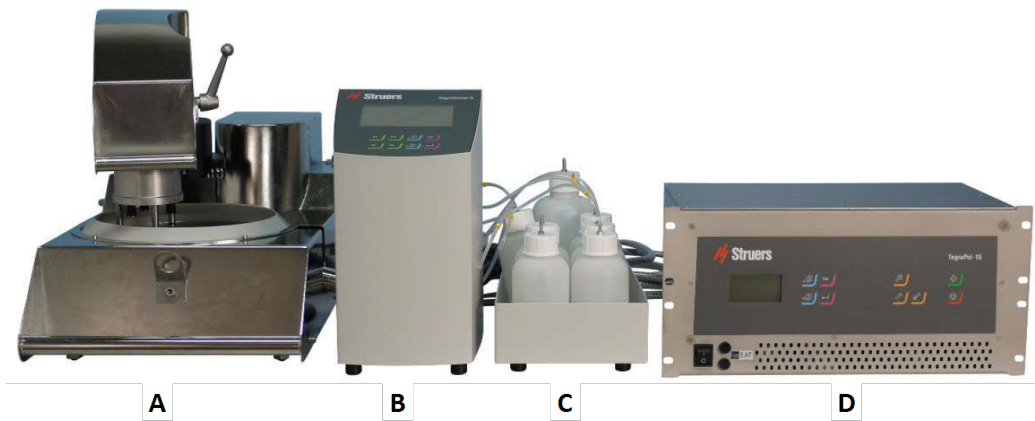

- A** TegraSystem Remote
- B** TegraDoser Remote
- C** TegraDoser Remote bottle unit
- D** Control box

Front view

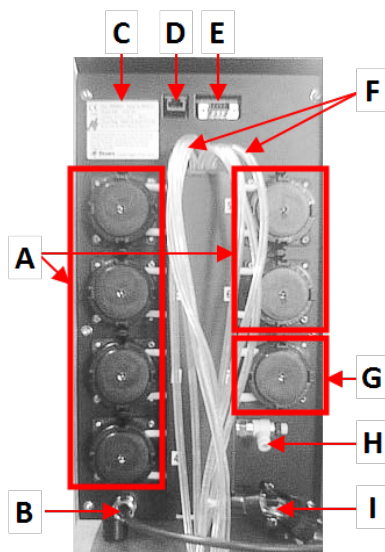

- A** TegraDoser Remote
- B** Bottle unit with bottles

**Rear view**

- A** 6 pumps for diamond suspension or lubricant
- B** Communication cable/Power supply cable
- C** Type plate
- D** Network connection
- E** Service socket
- F** Supply tubes from doser
- G** Pump for water
- H** Not used
- I** Tube connection - for dosing head on TegraSystem Remote

8.1 Installation

8.1.1 Unpack the machine

**Note**

We recommend that you keep all original packaging and fittings for future use.

1. Cut the packing tape on the top of the box.
2. Remove the loose parts.
3. Remove the unit from the box.

8.1.2 Check the packing list

Optional accessories may be included in the packing box.

The packing box contains the following items:

Pcs.	Description
1	TegraDoser Remote
1	Dosing bottle unit
1	Screw - for securing the dosing head
6	Silicone tubes for the pump for alcohol-based products
1	Dummy plug for the control box
7	Bottles for water, suspensions and lubricants
1	Communication cable: TegraDoser Remote - Control box
1	Instruction Manual set

8.1.3 Location

TegraDoser Remote (option)

- Place the device on a level and stable surface outside the enclosed area.
1. Place TegraDoser Remote as close to the TegraSystem Remote control box as possible.
 2. The unit is supplied with the tubes connected.

8.1.4 Powering TegraDoser Remote



ELECTRICAL HAZARD

Switch off the electrical power supply before installing electrical equipment.
The machine must be earthed (grounded).
Make sure that the actual electrical power supply voltage corresponds to the voltage stated on the type plate of the machine.
Incorrect voltage can damage the electrical circuit.

Procedure

1. Switch off the control box.
2. Connect the communication cable from TegraDoser Remote to the control box. (A)
3. Mount the dummy plug in the socket on the control box. (A)

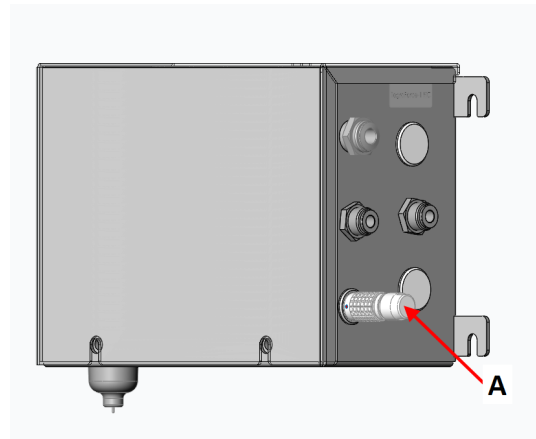
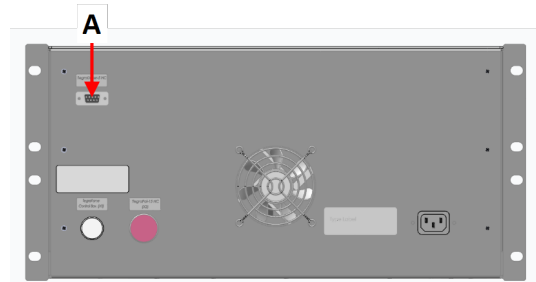

A Dummy plug

8.1.5 Installing TegraDoser Remote

TegraDoser Remote is supplied with a 7-nozzle dosing head with tubing for mounting on the specimen mover.

- A Dosing head connection

Fitting the dosing head to the specimen mover

1. Insert the dosing head into the recess on the side of the specimen mover. **A** Dosing head connection

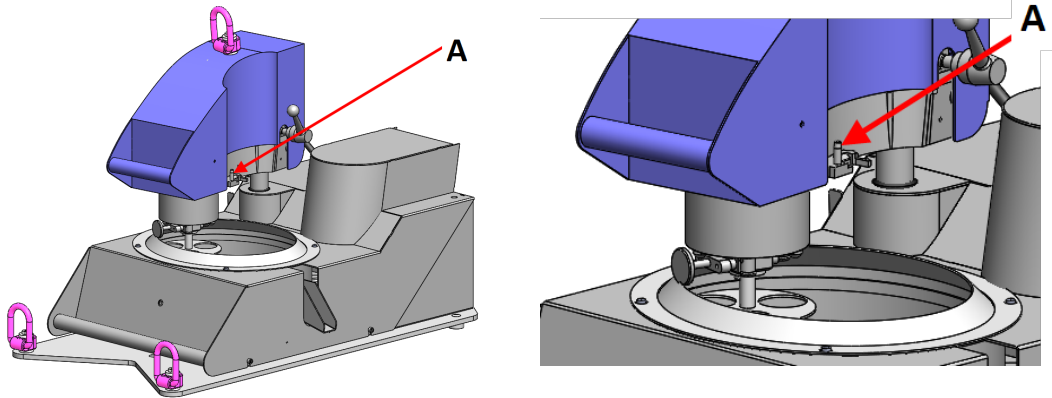

2. Press downwards until the dosing head is in position.
3. Insert the included screw and tighten it to secure the dosing head.
4. Make sure that the tubes from TegraDoser Remote are not stretched tightly. The specimen mover must be able to turn freely.

Removing the dosing head from the specimen mover

1. Loosen the securing screw located on the top of the dosing head.



Note

Make sure that the tubes do not get caught on the specimen mover when you lift the dosing head clear.

2. Grip the top and bottom of the dosing head and pull it upwards until it is free of the specimen mover.

8.1.6 Mounting tubes on doser bottles

1. Mount the tubes on the bottles by connecting them to the nipple on the top of the bottles.

8.1.7 Changing lubricant/suspension

Struers recommends using a separate bottle cap for each consumable.

To use the bottle cap with another consumable:

1. Remove the bottle.
2. Hold the bottle firmly and remove the bottle cap.
3. Empty the bottle and fill it with a mild soap solution.
4. Open the valve and clean the dosing nozzle.







5. Exchange the soap water with clean water and repeat the above procedure.
6. Put the bottle cap on a Struers lubricant/suspension bottle.

8.2 Operating TegraDoser Remote

8.2.1 Control panel functions

The buttons on the TegraDoser Remote control panel apply specifically to operating TegraDoser Remote:



Button	Function
 - 	Function key <ul style="list-style-type: none"> Press this button to activate controls for various purposes. See the bottom line of the individual screens.
	Scroll up <ul style="list-style-type: none"> Press this button to scroll up in a screen and to increase the value of a setting.
	Scroll down <ul style="list-style-type: none"> Press this button to scroll down in a screen and to decrease the value of a setting.
	Escape <p>Use this button on the control panel to return to previous functions or values.</p> <ul style="list-style-type: none"> Press the button to return to the main menu. Press the button to return to the last function or value. Press the button to cancel changes.
	Select/Enter <ul style="list-style-type: none"> Press this button to enter a field, for instance a setting, to select a value, and to confirm a selection.

8.2.2 The display



Note
The screens shown in this manual may differ from the actual screens in the software.

When you switch on the machine, the display shows the configuration and the version of the installed software.

After start-up, the display changes to the screen last shown when the machine was switched off.

The display is divided into some main areas. See this example.

A Title bar

The title bar shows the function you have selected.

B Information fields

These fields show information about the selected function. In some fields you can select and change the value.

C Function key options

The functions shown depend on the screen that is displayed.

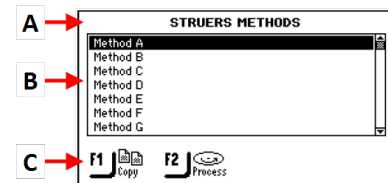

Navigating in the display

Use the buttons on the control panel to navigate in the display.

See [Control panel functions](#) ► 38.

Sound	Description
Short beep	A short beep, when you press a key, indicates that the selection is confirmed. You can enable or disable the beep: select Configuration .
Long beep	A long beep, when you press a button, indicates that the key cannot be activated at the moment. You cannot disable this beep.

Standby mode



To increase the lifetime of the display, the backlight is dimmed automatically if the machine has not been used for a while. (30 min)

- Press any key to reactivate the display.

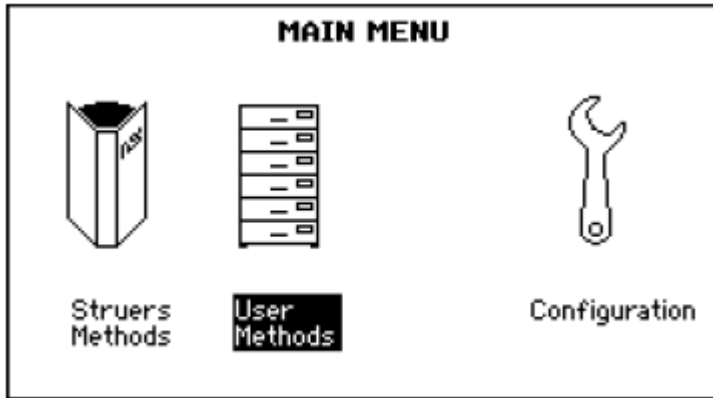
8.2.3 Main menu



From the **Main menu** screen you can choose between the following options:

- **Struers Methods**

- **User Methods**

- **Config.**

See

- [Preparation methods ▶ 49](#)
- [Configuration ▶ 43](#)

8.2.4 Changing settings and text

Changing text

To change a text value, select the field for entering the text.

1. Place the cursor on the character you wish to change.
 - F1**: Move the cursor to the left.
 - F3**: Move the cursor to the right.
2. Go to the character set.

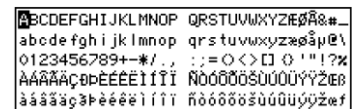

3. Move the cursor and select the characters you wish to enter.
 - **F1**: Move the cursor to the left.
 - **F2**: Delete one character in the text.
 - **F3**: Move the cursor to the right.
 - **F4**: Insert a space in the text.
4. Place the new character in the text and move the cursor.
5. Repeat the procedure for each character.
6. Save the changes.
7. Exit the text editor.

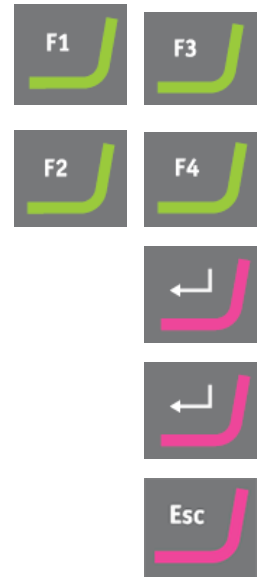

Change the settings

To change a setting, select the field for changing the setting.

1. Select the setting you wish to change.
 - If it is a numeric value, two square brackets [] appear around the value.
 - If it is an alphanumeric value, a pop-up menu appears.
2. Select the desired value.
 - If there are two values, toggle between the values.
3. Save the changes.
4. Confirm your changes.



8.2.5 Setting up the preparation process

When TegraDoser Remote is connected to TegraSystem Remote, you can perform an entire preparation process.

Before you start using preparation methods, set up the bottle configuration. See [Bottle configuration ▶ 44](#).

For instructions on how to use preparation methods and configure the equipment, see:

- [Configuration ▶ 43](#)
- [Preparation methods ▶ 49](#)

Procedure

Select a preparation method from the control panel on the control box.

1. From the **Main menu** screen, select **Preparation**.
2. Confirm your selection.
A list of method groups is shown.
3. Select the method group containing the preparation method you wish to use.
The method group shows a list of preparation methods.
4. Select the preparation method you wish to use.
5. If needed, view the steps included in the preparation method.
6. Select the desired step in the preparation process.
7. Make sure that the specimen mover is locked in position before you start the process.



The equipment is now ready for the preparation process to start. See [Starting and stopping the preparation process ▶ 62](#).

8.2.6 Settings - TegraDoser Remote

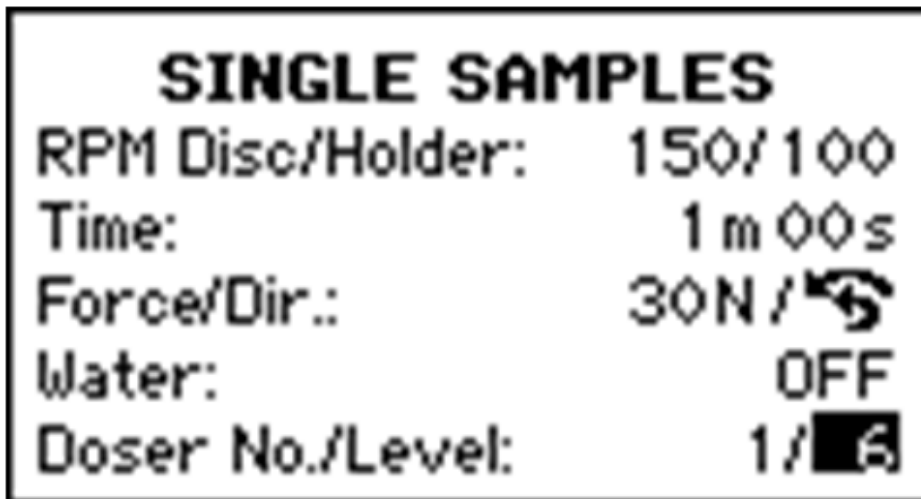

1. From the **Main menu** screen, select **Preparation**.
2. Confirm your selection.



3. To access the dosing parameters, set **Water** to **Off**.
4. If needed, select the preparation settings you wish to use.

Select the desired settings for **Doser No./Level**.

Settings	
RPM Disc/Mover plate	
Disc	40 - 600. In increments of 10.
Mover plate	50 - 150. In increments of 10.
Time	From 5 s to 1 min. In steps of 5 s.
	From 1 min to 5 min. In steps of 10 s.
	From 5 min to 60 min. In steps of 30 s.
Force/Dir.	10-50 N in steps of 5 N. Clockwise/Counter-clockwise

When TegraDoser Remote is connected to TegraSystem Remote, you must set the dosing level from the control panel.

Settings	
Doser No./Level	
Doser No.	Indicates the selected dosing bottle number in the bottle tray. Settings: 0 - 7
Level	Settings: 0 - 20. In increments of 1. Suspension = 0-10 Lubricant = 0-20

8.3 Configuration

CONFIGURATION MENU
Bottle Configuration
User Surface Configuration
User Suspension Configuration
User Lubricant Configuration
Options
Operation mode
LAN Module

You can change general settings in the **Configuration** menu.

You can also define new surfaces, lubricants and suspensions.

Selecting the Configuration screen

1. From the **Main menu** screen, select **Config.**
2. From the **Configuration** screen, select:



- [Bottle configuration](#) ▶ 44
- [Configuring a user surface](#) ▶ 45
- [Configuring a user suspension](#) ▶ 46
- [Configuring a user lubricant](#) ▶ 46
- [The Options screen](#) ▶ 47
- [Configuring operation mode](#) ▶ 48

8.3.1 Bottle configuration

 **Note**
You must configure this setting before you start using the machine.

Use this option to define which suspensions or lubricants you are using in the bottles connected to the pumps.

1. From the **Main menu** screen, select the **Configuration** screen.
2. Select the **Bottle configuration** screen.



3. Select the **Lub./Susp.** column.



4. Toggle between lubricant and suspension.



5. Select the column.



6. Toggle between the list of lubricants and suspensions.



7. Select the desired suspension or lubricant.



8. Confirm your selection.



9. Repeat the above steps for all bottles.
10. Return to the **Configuration** screen.



8.3.2 Configuring a user surface

You can define up to 10 new user-defined surfaces. You can define the name, the abrasive rule and the lubricant rule for each surface.



Note

Make sure that you select the correct rules for each surface, as this will affect the suspensions and lubricants that are available when you create a new preparation method.

Procedure

1. From the **Main menu** screen, select the **Configuration** screen.
2. Select the **User surface configuration** screen.



3. Select the **Surface name** column.
4. Select the row indicating the surface you wish to configure.
5. Open the text editor.
6. Enter the name of the new surface.
7. Select the **Abr. rule** column.



8. Select the **Select abrasive rule** screen.
9. Select the desired abrasive rule.
10. Confirm your selection.
11. Return to the **Configuration** screen.



8.3.3 Configuring a user suspension

You can define up to 10 new user-defined suspensions. You can define the name, the abrasion type and the lubricant rule for each suspension.

1. From the **Main menu** screen, select the **Configuration** screen.
2. Select the **User suspension configuration** screen.
3. Select the **Susp. name** column.
4. Select the row indicating the suspension you wish to configure.
5. Open the text editor.
6. Enter the name of the new suspension.
7. Select the **Abr. type** column.
8. Select the **Select abrasive type** screen.
9. Select the desired abrasive type.
10. Select the **Lub. rule** column.
11. Confirm your selection.
12. Select the **Select lubricant rule** screen.
 - If the suspension used requires the use of a lubricant, select **Other lub. except water**.
 - If the suspension does not require a lubricant, select **No lubricant**.
 - If the abrasive is only to be used with water-free lubricants, select **Only waterfree lubricants**.
13. Confirm your selection.
14. Return to the **Configuration** screen.



8.3.4 Configuring a user lubricant

You can define up to 10 new user-defined lubricants. You can define the name and the lubricant type.

1. From the **Main menu** screen, select the **Configuration** screen.
2. Select the **User lubricant configuration** screen.
3. Select the **Lubricant name** column.
4. Select the row indicating the lubricant you wish to configure.
5. Open the text editor.
6. Enter the name of the new lubricant.
7. Select the **Lubricant type** column.
8. Select the row indicating the lubricant you wish to configure.
9. Open the **Select lubricant type** list.
 - If the lubricant contains water, select **Lubricant containing water**.
 - If the lubricant is waterfree, select **Waterfree lubricant**.
10. Confirm your selection.
11. Return to the **Configuration** screen.



8.3.5 The Options screen

From the **Options** screen you can set up the display.

- If needed, you can reset some settings to their factory default value: Press function key **F1** when the value is highlighted.



1. From the **Configuration** screen, select the **Options** screen.
You can change the following settings:

Option	Setting
Display contrast	You can adjust the display to make it easier to view.

2. Select the setting.
3. Change the value of the setting.



4. Confirm your selection.



5. Return to the **Main menu** screen.



8.3.6 Configuring operation mode

You can restrict access to the software in the **Operation mode** screen.

1. From the **Main menu** screen, select the **Configuration** screen.
2. Select the **Operation mode** screen.
3. Select **Current operation mode**.



4. Enter the pass code.
The default pass code is **176**.



5. Confirm the pass code.



6. Select the operation mode.



The options are:

Operation mode	Preparation	Change the settings	Configuration functions
Process	You can select and view settings.	You can select and view methods.	You can edit some settings.
Development	You can select, view and edit settings.	You can select, view and edit methods.	You can edit some settings.
Configuration	You can select, view and edit settings.	You can select, view and edit methods.	You can edit all settings.

7. Confirm your selection.



8.3.7 New pass code

When you access the **Operation mode** screen, you will be prompted to enter a pass code.

Changing the pass code

You can change the pass code from the **Operation mode** screen.



Note

Make a note of the new pass code.
The default pass code is **176**.

To change the pass code, do the following:

1. From the **Main menu** screen, select the **Configuration** screen.
2. Select the **Operation mode** screen.
3. Select the **Pass code** field.



4. Enter the pass code.



5. Select the **New pass code** field.



6. Enter the new pass code.
Remember to make a note of the new pass code.



7. Confirm the new pass code.



8.4 Preparation methods

You can save preparation methods that have common attributes, such as being used on the same class or type of materials, into method groups. See [Method groups ▶ 50](#).

- You can create up to 10 method groups.
- You can store up to 20 preparation methods in a method group.

User methods

The software includes 10 Metalog Guide methods, which you can use to set up your preparation methods.

Each method contains a number of method steps that are required for the preparation process.

You can work with the following types of methods:

- **Struers Methods**

These methods are predefined. You cannot change the settings. If needed, copy them into the **User Methods** folder, and change the settings.

- **User Methods**

These methods you can copy and change as needed.

See [Selecting a method ▶ 51](#).

Creating a preparation method

You can create a preparation method in several ways:

- Create a preparation method. See [Creating a preparation method ▶ 52](#).
- Change a preparation method and save it under another name. See [Editing a method ▶ 54](#)

8.4.1 Method groups

- You can create up to 10 method groups.

Creating a method group

1. From the **Main menu** screen, select the **User Methods** screen.
2. In the **Method groups** screen, select **Empty Group**.
3. Copy the group.
4. Insert the new group.
5. If needed, rename the group. See [Changing settings and text ▶ 40](#)



Selecting a method group

1. From the **Main menu** screen, select the **User Methods** screen.
2. Select the method group you wish to use.
The method group contains the methods you have saved in this group.



Deleting a method group

If you wish to delete a method group, you must first move or delete the methods in the method group.

1. From the **Main menu** screen, select the **User Methods** screen.



2. Select the method group you wish to delete.



3. Before you can delete the method group, move or delete the methods in the method group.
4. Delete the method group.



8.4.2 Selecting a method

1. From the **Main menu** screen, select **User Methods**



2. Select the method you wish to use.



3. Confirm your selection.



8.4.3 Copying a preparation method

- Copy a Struers method from the **Struers Methods** folder, and save it in the **User Methods** folder.

or

- Copy an existing method from the **User Methods** folder.

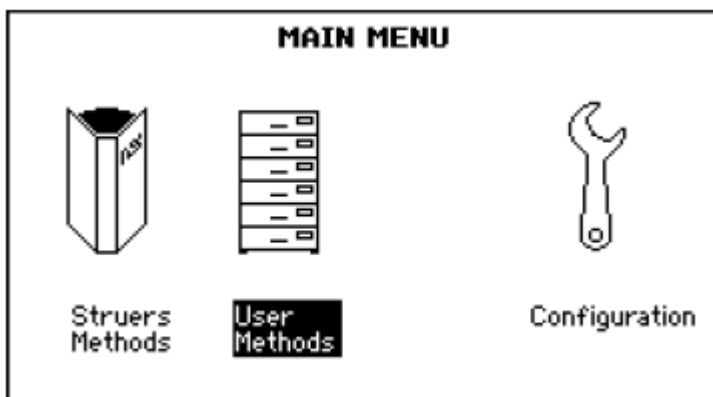

- Save the method in the **User Methods** folder or in a **Method groups** folder.
- Rename the method.
- Edit the method. See [Editing a method](#) ► 54.

Procedure

1. From the **Main menu** screen, select one of the following screens:

- **Struers Methods**

or

- **User Methods**



2. Select the method you wish to use.



3. Copy the method.



4. Confirm your selection.



5. Select the **User Methods** screen.



6. Select the method group or the field where you want to insert the new method.



7. Insert the method.

8. If you are using an empty method, the name automatically changes from **Empty method** to **Unnamed method**.



9. Confirm your selection.



10. Rename the method. See [Changing settings and text ▶ 40](#).

The user method must contain at least one method step before you can rename it.



11. If needed, edit the method. See [Editing a method ▶ 54](#).

8.4.4 Creating a preparation method

- Select an empty method in the **User Methods** folder.

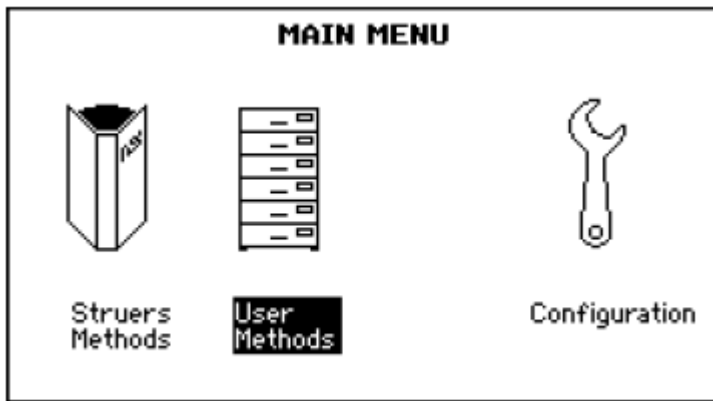

- Edit the method.
- Save the method in the **User Methods** folder or in a **Method groups** folder. See [Changing settings and text ▶ 40](#).

Procedure

1. From the **Main menu** screen, select **User Methods**



2. Select **Empty Group > Empty method**.



3. In the **Empty method - Step No. 1** screen, edit the settings needed for the preparation step. See [Editing a method ▶ 54](#).
4. When you have changed the required settings, press **F2 - Next step**.



5. When you have created and changed the required preparation steps, save the preparation method.



- **Save method**

Save the method in the current method group under the current method name.

or

- **Save method as**

If needed, select a new method group and save the method under a new method name.

The user method must contain at least one method step before you can rename it.

8.4.5 Moving a method

1. From the **Main menu** screen, select the **User Methods** screen.
2. Select the method you wish to move.
3. Copy the method.
4. In the **User Methods** screen, select the method group or the field where you want to insert the new method.
5. Insert the method.



8.4.6 Deleting a method

1. From the **Main menu** screen, select the **User Methods** screen.
2. Select the method you wish to delete.
3. Delete the method.
4. Confirm your selection.



8.4.7 Editing a method

You can add up to 20 steps in a user method. Each method step contains a list of process settings which you must define and save before you can add the method step to a user method.

You can copy and insert existing user method steps in other user methods.

Copying a step from an existing method

1. Select the method containing the step you wish to copy.
The **Edit method** screen is shown.
2. Select the step you wish to copy.



3. Copy the step.
4. Select the method where you wish to insert the step.
5. Insert the step.



Editing user method steps

See [Editing user method steps](#) ► 56

8.4.8 Creating a method step

You can either copy a method step and insert it into the method you wish to edit, or create a method step from an empty step.

Copying a method step

1. Select the method containing the method step you wish to copy.
2. Access the method.
3. Select the method step you wish to copy.
4. Copy the method step.
5. Select the method where you wish to insert the method step.
6. Insert the method step.
7. Save your changes.



Creating a method step

1. From the **Main menu** screen, select the **User Methods** screen.
2. Press **Enter** to activate the **Method groups** screen.



3. In the **Method groups** screen, select the method group containing the user method you wish to edit.
4. Press **Enter** to open the method group.
5. Select the method you wish to edit.
6. Press **Enter** to edit the method.
7. Select **Empty Step**.
8. Edit the step. See [Editing user method steps](#) ▶ 56
9. Save your changes.



8.4.9 Editing user method steps

You can change the settings for each step in a preparation method.

You can use two or more method steps as “phases” in a method step. For instance, when the same surface, suspension and lubricant are used, you can change the other settings for force and dosing level to obtain a finer surface finish or gentler start or finish of the preparation step. You can define individual preparation times for these “phases”, and they will be carried out successively without stopping the process.

Settings														
Surface Suspension Lubricant	<p>There are two types of polishing surfaces:</p> <ul style="list-style-type: none"> • Abrasive • Non-abrasive <p>The settings shown depend on the type of polishing surface you have selected. See Defining surfaces, lubricants and suspensions ► 59</p> <table border="1"> <thead> <tr> <th>Surface</th> <th></th> <th></th> </tr> </thead> <tbody> <tr> <td>Abrasive</td> <td>Not required</td> <td>Water only</td> </tr> <tr> <td rowspan="3">Non-abrasive</td> <td>Diamond suspension. DiaPro or DiaDuo (all-in-one products)</td> <td>Not required</td> </tr> <tr> <td>Diamond suspension (Water-based)</td> <td>Water-based</td> </tr> <tr> <td>Diamond suspension (Water-free)</td> <td>Water-free</td> </tr> </tbody> </table>	Surface			Abrasive	Not required	Water only	Non-abrasive	Diamond suspension. DiaPro or DiaDuo (all-in-one products)	Not required	Diamond suspension (Water-based)	Water-based	Diamond suspension (Water-free)	Water-free
Surface														
Abrasive	Not required	Water only												
Non-abrasive	Diamond suspension. DiaPro or DiaDuo (all-in-one products)	Not required												
	Diamond suspension (Water-based)	Water-based												
	Diamond suspension (Water-free)	Water-free												
Level	<ul style="list-style-type: none"> • Select the dosing level. See Setting dosing levels ► 60. 													
Process time	<ul style="list-style-type: none"> • Select a specified length of time for the process. <p>From 5 s to 1 min. In steps of 5 s. From 1 min to 5 min. In steps of 10 s. From 5 min to 60 min. In steps of 30 s.</p>													
Force	<ul style="list-style-type: none"> • 10-50 N in steps of 5 N. 													
Disc rotation speed	<ul style="list-style-type: none"> • 40 - 600. In increments of 10. 													
Specimen mover speed / direction	<p>50 - 150. In increments of 10 Clockwise/Counter-clockwise.</p>													

Procedure

1. From the **Main menu** screen, select the **User Methods** screen.
2. Press **Enter** to activate the **Method groups** screen.
3. In the **Method groups** screen, select the method group containing the user method you wish to edit.
4. Access the method group.



5. Select the method you wish to edit.



6. Confirm your selection.



7. Move up or down the method steps.



8. Select the method step you wish to edit.



9. Select the setting you wish to edit.



10. Confirm your selection.



11. Edit the setting.



12. Confirm your selection.



13. Save your changes.



8.4.10 Deleting a user method step

1. From the **Main menu** screen, select the **User Methods** screen.

2. Press **Enter** to activate the **Method groups** screen.



3. Select the method group containing the user method you wish to edit.



4. Confirm your selection.



5. Select the method you wish to edit.



6. Confirm your selection.



7. Select the method step you wish to delete.



8. Delete the step.



8.4.11 Defining surfaces, lubricants and suspensions

Before you can define these settings you must first select the type of consumable.

The lists of available consumables depend on the surface you have defined. Use the same method to select surfaces, lubricants and suspensions.

As many different consumables are available, they are divided into the following groups:

- Product groups, e.g. MD products
- Product names, e.g. MD-Largo

Procedure

1. From the **Main menu** screen, select the **User Methods** screen.

2. Press **Enter** to activate the **Method groups** screen.



3. Select the method group containing the user method you wish to edit.



4. Confirm your selection.



5. Select the method you wish to edit.



6. Confirm your selection.



7. Select the method step you wish to edit.











8. Confirm your selection.



9. Select the setting you wish to edit.



10. Confirm your selection. 
11. Select the correct setting for the consumables **Surface, Lubricant** and **Suspension**.  
12. Confirm your selection. 
13. Move up or down the list of consumables.  
14. Select the consumable. 
15. Confirm your selection. 
16. Save your changes.
The method is automatically sent to TegraSystem Remote. 

8.4.12 Setting dosing levels

When suspensions and/or lubricants are used in a preparation step, you must first select the type of suspension or lubricant, and then the dosing level.

In the **Level** field, you can set two values:

- Pre-dosing: the amount of suspension or lubricant applied onto the surface before the actual step is started.
- Dosing: this is the dosing level used during preparation. Set this level according to the type of surface you have selected.



For **Level** you can set two values: e.g. 2/7 (pre-dosing/dosing).

Option	Pre-dosing	Dosing	Increment
Dosing level	0 - 10	0 - 20	1

Example



The pre-dosing level [e.g. 2]

This value is the pre-dosing level, the amount of suspension or lubricant which is applied to the surface before the actual preparation step is started.

This lubricates the surface to prevent damage from occurring if the specimens were to run on a dry surface.

Applicable values depend on the frequency of use and surface types. For frequently used surfaces, use a lower value than for surfaces used infrequently.



The dosing level [e.g. 7]

This value is the dosing level throughout the preparation. This level is set according to the surface types: soft, napped polishing cloths require more lubricant than hard, flat cloths or fine grinding discs.

Fine grinding discs require a lower dosing level of abrasive than polishing cloths.

Procedure

1. From the **Main menu** screen, select the **User Methods** screen.
2. Press **Enter** to activate the **Method groups** screen.



3. Select the group containing the user method you wish to edit.



4. Confirm your selection.



5. Select the method you wish to edit.



6. Confirm your selection.



7. Select the method step you wish to edit.



8. Confirm your selection.



9. Select the setting you wish to edit.



10. Confirm your selection.



11. Select the correct settings for **Level**.



12. Confirm your selection.



13. Save your changes.



Changing dosing levels during a process

You can always change dosing levels for suspensions and lubricants during a process. See [Defining surfaces, lubricants and suspensions](#) ► 59.

8.5 The preparation process

8.5.1 Starting and stopping the preparation process

Start the machine

1. Select the desired preparation method.
2. Make sure that the grinding or polishing surface is correctly mounted.
3. Make sure that the driving pins on the preparation disc engage with the holes in the turntable.
4. Insert the specimens in the specimen mover plate.
5. Press the Start button on the control panel to start the preparation.
The disc and the specimen mover plate start turning at the pre-set speed.
The pressure feet move down.
6. Water, suspension and/or lubricant is applied automatically.
If you perform two consecutive preparation steps with the same surface, suspension and lubricant, the machine does not stop between these two steps.
They are considered to be 2 phases of the same step.
If you wish to stop the machine between two consecutive steps, e.g. to change SiC Paper, see [Machine Configuration](#) ► 29.



Stopping the machine

The machine stops automatically when the preset preparation time has expired.

8.5.2 Changing settings during preparation

When a preparation step is running, you can only change the setting for force, and the dosing levels for suspensions and lubricants.

If you wish to change other settings you must stop the process.

Stopping the machine

- Press the **Stop** button.

**Change the settings**

1. Select the preparation method being used.
2. Select the step that is being performed: Press **F2 Process**.
3. Change the setting.

**Start the machine**

1. Press the Start button on the control panel to start the preparation.



9 Maintenance and service

Proper maintenance is required to achieve the maximum up-time and operating lifetime of the machine. Maintenance is important in ensuring continued safe operation of your machine.

The maintenance procedures described in this section must be carried out by skilled or trained personnel.

Maintenance tasks

For instructions on how to carry out maintenance, see the following sections:

- [Daily ▶ 65](#)
- [Weekly ▶ 65](#)
- [Monthly ▶ 66](#)

Technical questions and spare parts

If you have technical questions or when you order spare parts, state serial number and voltage/frequency. The serial number and the voltage are stated on the type plate of the machine.

9.1 General cleaning

To ensure a longer lifetime for your machine, we strongly recommends regular cleaning.

Note
On the units outside the enclosed area: Do not use acetone, benzol or similar solvents.

If the machine is not to be used for a longer period of time

- Clean the machine and all accessories thoroughly.

9.2 Change the tubes

When you use alcohol-based lubricants, the Novoprene tubes mounted in the pumps will harden over time. Silicone has a better resistance against alcohol.

You can replace the tubes with the set of silicone tubes supplied with the unit.

Procedure

1. Disconnect the doser tubes at the white connectors. (A)
The white connectors must remain on the tubes connected to the pump.
2. Press the two tabs at the base of the pump and remove the pump from the axle. (B)

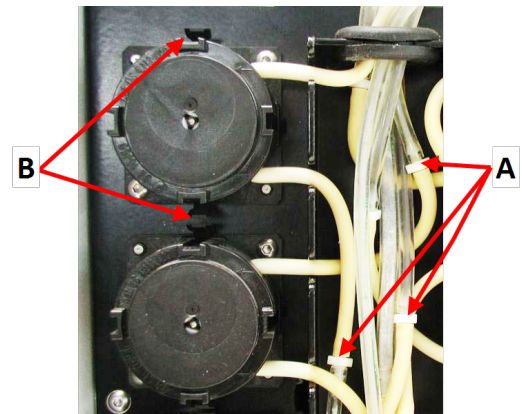

A White connectors

B Tabs

3. Press the two tabs at the base of the pump and remove the bottom cover. (A)

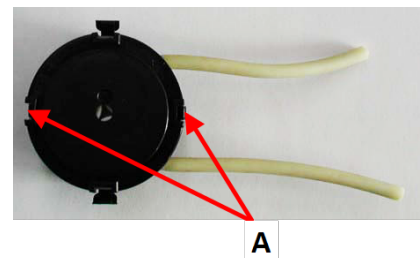

4. Remove the three rollers.
5. Remove the Novoprene tube.
6. Fit the new tube into the housing and press it firmly into place.



7. Press the three rollers into the pump housing.
8. Remount the bottom cover.



9. Press the pump back onto the axle.
10. Reconnect the tubes.
11. Make sure that the tubes are connected correctly so that liquid is pumped to the specimen mover.

9.3 Daily

TegraSystem Remote

- Clean all accessible surfaces with a soft damp cloth and common household detergents.



Note

On the units outside the enclosed area: Do not use acetone, benzol or similar solvents.

- Check the bowl liner and clean or dispose of it when it is filled with debris.

TegraDoser Remote

- Clean all accessible surfaces with a soft, damp cloth.
- Check and refill dosing bottles as needed.

9.4 Weekly

- Clean all accessible surfaces with a soft damp cloth and common household detergents.

Procedure

1. Remove the grinding/polishing disc and the splash guard.
2. Remove all dirt from the drain outlet.
3. Remount the splash guard and grinding/polishing disc.
4. Clean the pressure feet and pistons by applying force on the specimens:
 - From the **Main menu** screen, select **Configuration**.
 - Select **Single sample cleaning**.
 - Press Start. The pressure feet move downwards.
 - Use a dry cloth to clean the pressure feet and the pistons.
 - Press Stop. The pressure feet move upwards.
5. Press the release outlet valve on the air control unit to drain the water/oil filter. See [Empty the water/oil filter ▶ 66](#)



9.5 Monthly

9.5.1 Empty the water/oil filter

The air control unit is fitted with a water/oil filter that removes excessive amounts of water and oil from the compressed air supply.

The filter must be emptied on a regular basis.

Procedure

If the air control unit is located outside the enclosed area, the water/oil is filtered from the compressed air before it enters the enclosed area.

1. Locate the release outlet valve at the bottom of the air control unit. (A)
2. Hold a container under the release outlet valve and press the valve to empty the water/oil filter.

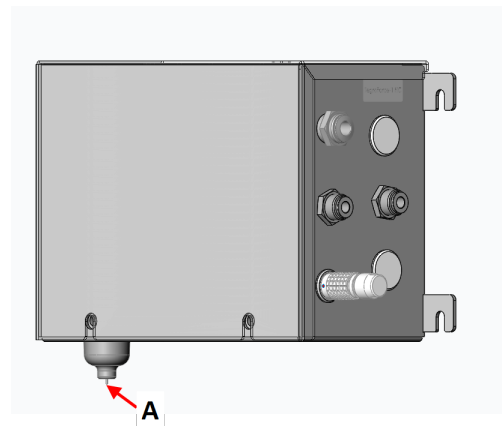

10 Spare parts

Technical questions and spare parts

If you have technical questions or when you order spare parts, state the year of production. The year of production is engraved on the cylinder arm.

For further information, or to check the availability of spare parts, contact Struers Service. Contact information is available on [Struers.com](https://www.struers.com).

11 Disposal



Equipment marked with a WEEE symbol contains electrical and electronic components and must not be disposed of as general waste.

Contact your local authorities for information on the correct method of disposal in accordance with national legislation.

For disposal of consumables and recirculation fluid, follow local regulations.

12 Troubleshooting

12.1 Troubleshooting

Polishing unit

Error	Cause	Action
Noise when the machine starts or the machine will not pull.	The belt is not tight enough.	The belt must be tightened.
Functions are not carried out. Machine not operating.	The fuse in the polishing unit has blown.	Replace the fuse.
The disc vibrates.	Dirt on the underside of the disc or on the turntable.	Clean the contact face between the disc and turntable.
Continuous, irregular wear on a grinding/polishing surface.	The coupling on either the specimen mover plate or the specimen mover head is worn.	The coupling must be replaced.

TegraDoser Remote

Error	Cause	Action
Maximum 20 steps!	Each method can contain a maximum of 20 method steps.	
Method database is full!	The User Methods database is full.	Delete user methods that are not required.
Method group is full!	Each method group can contain a maximum of 20 methods.	Delete existing methods that are not required.
Cleaning not allowed during dosing process!	It is not possible to perform cleaning while a process is running.	Clean the tubes after the process is completed.
Suspension and lubricant not compatible!	The selected user lubricant does not have the correct type or cannot be used with the selected suspension. Example: The selected suspension cannot be used with water-based lubricants.	Change the Type for the lubricant or select another lubricant.
Surface and suspension not compatible!	The selected suspension does not have the correct Abr. type setting or cannot be used with the selected surface.	Change the Abr. type or select another suspension.
Dosing denied, the following suspension is not configured: DP-P 9 µm (Example)	The preparation process cannot start because the required suspension is not configured in TegraDoser Remote.	Open the Bottle configuration screen and set up the required suspension. Example: DP-P 9 µm.
Dosing denied, the following lubricant is not configured: Blue (Example)	The preparation process cannot start because the required lubricant is not configured in TegraDoser Remote.	Open the Bottle configuration screen and set up the required lubricant. Example: Blue.
The method is used for process, certain functions are not allowed!	The function cannot be performed because the method is being used in a process. Example: Methods cannot be deleted when they are being used in a process.	Wait until the process is completed before you perform the function.

Error	Cause	Action
Process in progress certain functions are not allowed!	The function cannot be performed while a process is running. Example: Bottle configuration cannot be changed when a process is running.	Wait until the process is completed before you perform the function.

12.2 Errors

Messages provide information about the machine's status and minor errors.

TegraSystem Remote

Error message	Cause	Action
NVRAM initialized	Default settings have been set for all non-volatile parameters.	No action required. The message disappears after a few seconds
Frequency inverter communication error		Switch off the machine. Switch on the machine. Try again. If the error remains, contact Struers Service.
Frequency inverter heat sink temp. too high		Switch off the machine. Let the machine cool down for a few minutes. Switch on the machine. Try again. If the error remains, contact Struers Service.
Frequency inverter internal temp. too high		Switch off the machine. Let the machine cool down for a few minutes. Switch on the machine. Try again. If the error remains, contact Struers Service.

Error message	Cause	Action
Frequency inverter unknown error: 1	Internal frequency inverter error.	Switch off the machine. Try again. If the error remains, contact Struers Service.
Motor temperature too high		Stop the process. Let the machine cool down for a few minutes. Try again. If the error remains, contact Struers Service.
Motor temp. sensor disconnected		Contact Struers Service.
Cannot read keyboard		Contact Struers Service.
Specimen mover head not locked		Lock the handle before you start the process.

TegraSystem Remote with TegraDoser Remote

Error message	Cause	Action
TegraDoser nozzle block not mounted	Nozzle block missing, or not correctly seated.	The dummy plug is not mounted.
Method not valid anymore	Method has been edited on TegraDoser	Reload the method by going back to the method list and selecting the method again.
Tube cleaning in progress		Wait for the cleaning process to finish.
Suspension not applicable	The suspension specified in the method has not been configured on TegraDoser	Configure the suspension in one of the pump positions, or select another suspension in the method.
Lubricant not applicable	The lubricant specified in the method has not been configured on the TegraDoser	Configure the lubricant in one of the pump positions, or select another lubricant in the method.

13 Technical data

13.1 Technical data sheet

Capacity	Individual specimens	Diameter: 3 x 40 mm
	Specimen MoverSpecimen mover	Diameter: 109 mm
Disc	Diameter	200 mm (8")
	Rotational speed	40-600 rpm, variable
	Rotational direction	Counter-clockwise
	Motor power	–
	- Continuous (S1)Continuous (S1)	370 W (0.5 hp)
	- Max. Max.	555 W (0.7 hp)
Specimen mover head	Individual specimen	–
	- Force	10-50 N in steps of 5 N
	- Specimen height	8 - 32 mm (0.31 - 1.26")
	Rotational speed	50-150 rpm, variable in steps of 10
	Rotational direction	Clockwise/Counter-clockwise
	Motor	52 W
	Torque	0.6 Nm (0.44 ft-lbf)
Options - TegraDoser Remote	Automatic dosing, up to 7 pumps	Yes
Software and electronics	Controls	Touch pad
	Display	LCD, TFT-BW 3.2", 128 x 64 dots with white LED backlight
Safety standards		CE-labeled according to EU directives
REACH		For information about REACH, contact your local Struers office.

Operating environment	Surrounding temperature	5-40°C (41-104°F)
	Humidity	35-85% RH non-condensing
Power supply	Voltage/frequency	200-240 V (50-60 Hz)
	Power, inlet	1-phase (N+L1+PE) or 2-phase (L1+L2+PE) The electrical installation must comply with Installation Category II
	Power, nominal load	440 W
	Power, idle load	12 W
	Current, nominal load	2.2 A
	Current, maximum load	5.0 A
	Current, largest load	2.3 A
Air supply	Pressure, compressed air	5 - 9.9 bar (72 - 143 psi)
	Flow, compressed air	3.5-4 l/m (1.1 gpm)
	Air quality, compressed air	The air supplied must be of Class 5.6.4. or better, as specified in ISO 8573-1
	Air inlet, compressed air, connection	Diameter: 6 mm (¼")
Residual Current Circuit Breaker (RCCB)		Type A, 30 mA (or better) is required
Noise level	A-weighted sound emission pressure level at workstations	LpA = 70 dB(A) (measured value). Uncertainty K = 4 dB (A) Measurements made in accordance with EN ISO 11202
Vibration level	Declared vibration emission	N/A

Dimensions and weight Polishing unit, Specimen mover	Height	55.5 cm (22")
	Width	50 cm (19.7")
	Depth	85.5 cm (33.7")
	Weight	51 kg (112 lb)
	Weight - with lifting platform	60 kg (132 lb)
Dimensions and weight Control Box	Height	22.5 cm (8.9")
	Width	48 cm (19")
	Depth	30 cm (11.9")
	Weight	11 kg (24.3 lb)
	Cables length (standard)	8 m (2 pcs) - max app. 20 m
Dimensions and weight Air Control Box	Height	17 cm (6.7")
	Width	27 cm (10.6")
	Depth	10.5 cm (4.1")
	Weight	2 kg (4.4 lb)
	Hose length (supply of compressed air)	8 m - max app. 20 m
	Hose length (supply to Force unit)	8 m - max

13.2 Noise and vibration levels

Noise level	A-weighted sound emission pressure level at workstations	$L_{pA} = 70 \text{ dB(A)}$ (measured value) Uncertainty $K = 4 \text{ dB}$ Measurements made in accordance with EN ISO 11202
Vibration level	N/A	

13.3 Diagrams

**Note**

If you want to view specific information in detail, see the online version of this manual.

Title	No.
Block diagram	16963050 A
Pneumatic diagram	16471000 B
Circuit diagram	See the diagram number on the type plate of the equipment, and contact Struers Service via Struers.com .

16963050 A

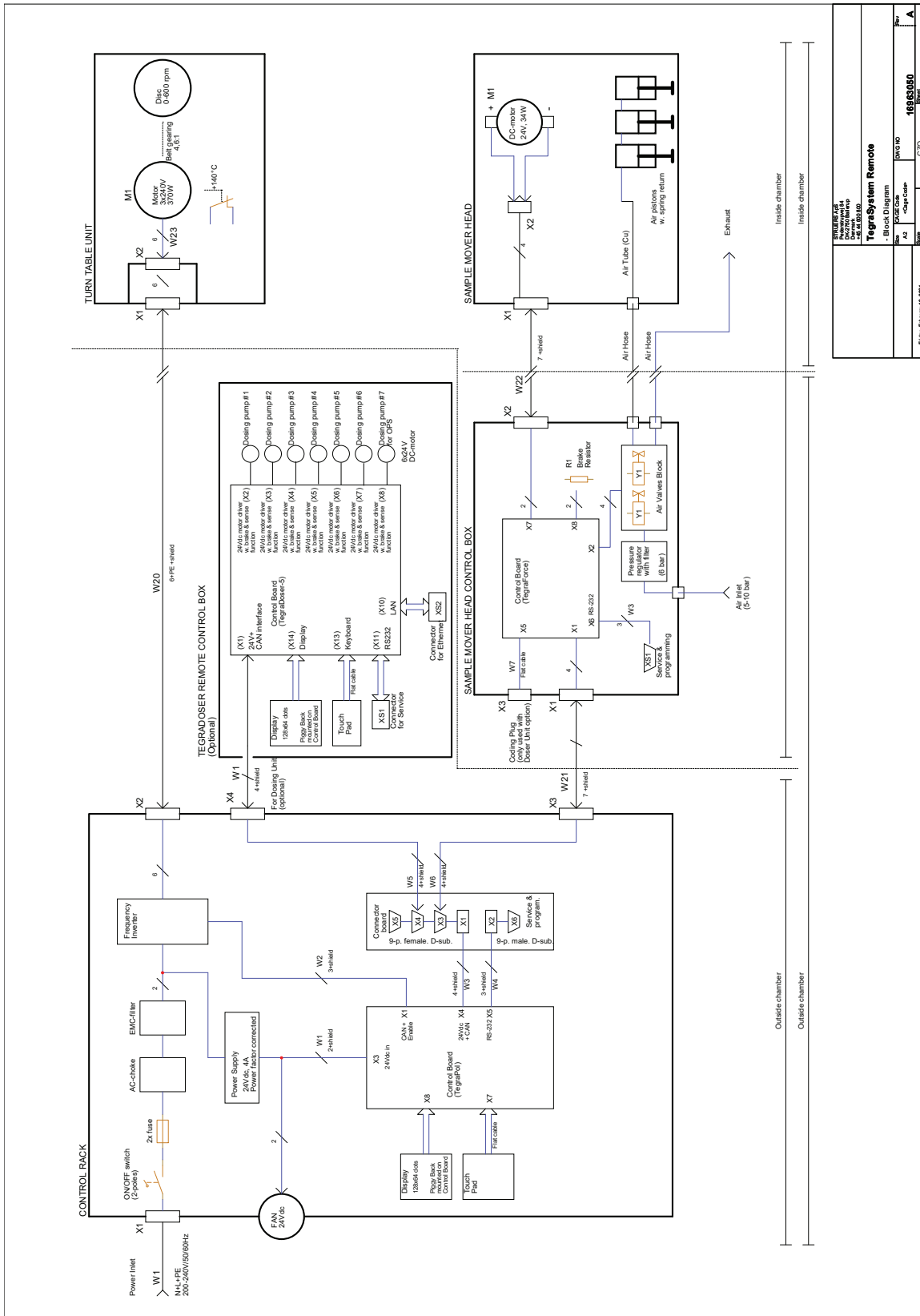

TEGRA SYSTEM REMOTE	
TegraSystem Remote	
Part No.	16963050
Rev.	A
Size	A3
Case Code	C2D
Printed	1 of 1

16471000 B

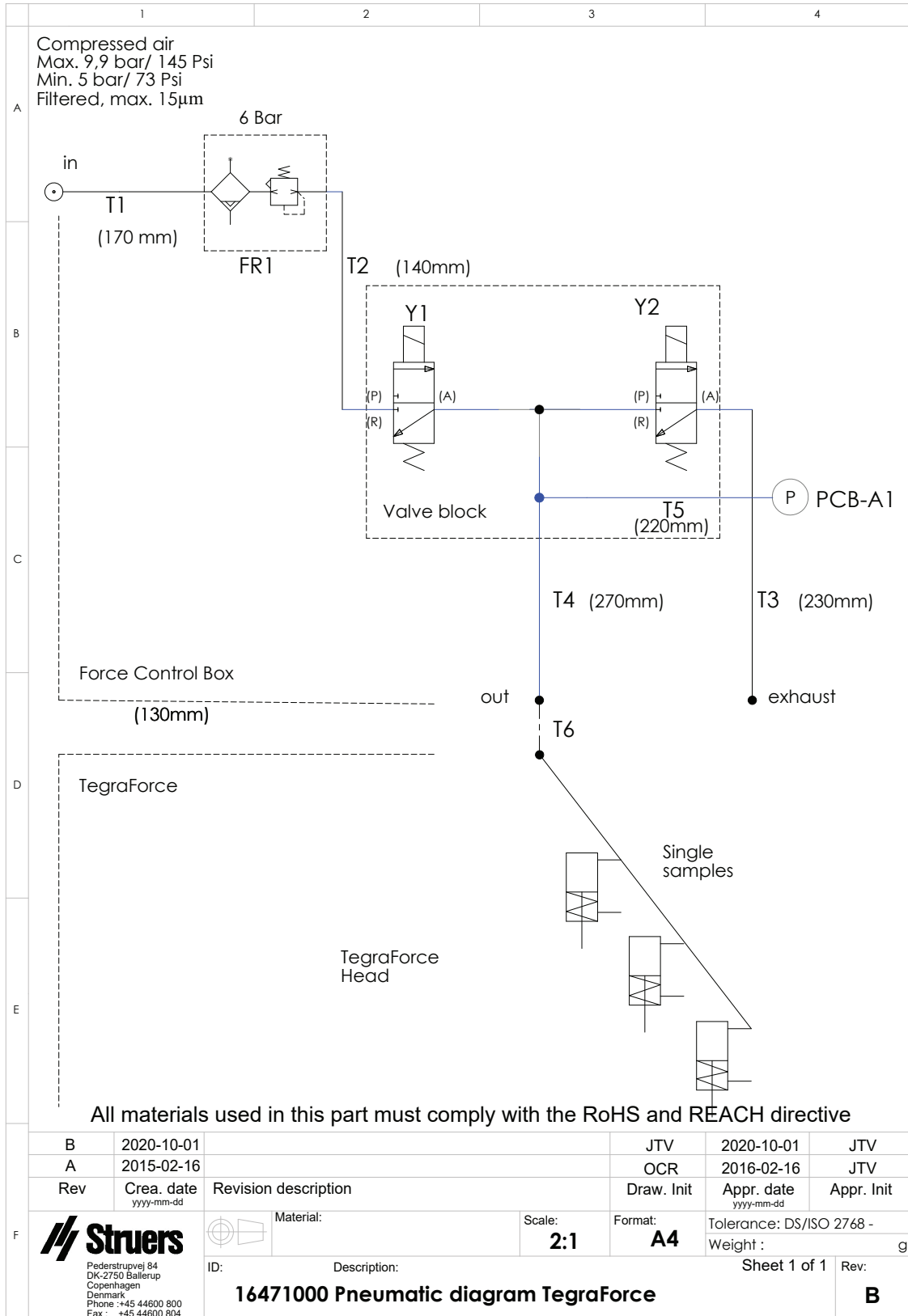

13.4 Legal and regulatory information

FCC notice

This equipment has been tested and found to comply with the limits for a Class B digital device, pursuant to part 15 of the FCC Rules. These limits are designed to provide reasonable protection against harmful interference in a residential installation. This equipment generates, uses and can radiate radio frequency energy and, if not installed and used in accordance with the instructions, may cause harmful interference to radio communications. However, there is no guarantee that interference will not occur in a particular installation. If this equipment does cause harmful interference to radio or television reception, which can be determined by turning the equipment off and on, the user is encouraged to try to correct the interference by one or more of the following measures:

- Reorient or relocate the receiving antenna.
- Increase the separation between the equipment and receiver.
- Connect the equipment into an outlet on a circuit different from that to which the receiver is connected.

14 Manufacturer

Struers ApS
Pederstrupvej 84
DK-2750 Ballerup, Denmark
Telephone: +45 44 600 800
Fax: +45 44 600 801
www.struers.com

Responsibility of the manufacturer

The following restrictions should be observed, as violation of the restrictions may cause cancellation of Struers legal obligations.

The manufacturer assumes no responsibility for errors in the text and/or illustrations in this manual. The information in this manual is subject to change without notice. The manual may mention accessories or parts not included in the supplied version of the equipment.

The manufacturer is to be considered responsible for effects on safety, reliability, and performance of the equipment only if the equipment is used, serviced, and maintained in accordance with the instructions for use.

Declaration of Conformity

Manufacturer	Struers ApS • Pederstrupvej 84 • DK-2750 Ballerup • Denmark
Name	TegraSystem Remote
Function	Polishing machine
Type	696
Cat. no.	06966127 And possible additional accessories equipment: 06967804, 06476900, 06476902, 06476903, 06476904, 06476905
Serial no.	



Module H, according to global approach



We declare that the product mentioned is in conformity with the following legislation, directives and standards:

2006/42/EC	EN ISO 12100:2010, EN 60204-1:2018, EN 60204-1-2018/Corr.:2020
2011/65/EU	EN 63000:2018
2014/30/EU	EN 61000-3-2:2014, EN 61000-3-3:2013, EN 61000-6-2:2005, EN 61000-6-2:2005/Corr.:2005, EN 61000-6-3:2007, EN 61000-6-3-A1:2011, EN 61000-6-3-A1-AC:2012
Additional standards	NFPA 79, FCC 47 CFR Part 15 Subpart B

Authorized to compile technical file/
Authorized signatory

Date: [Release date]

en For translations see
bg За преводи вижте
cs Překlady viz
da Se oversættelser på
de Übersetzungen finden Sie unter
el Για μεταφράσεις, ανατρέξτε στη διεύθυνση
es Para ver las traducciones consulte
et Tõlked leiate aadressilt
fi Katso käännökset osoitteesta
fr Pour les traductions, voir
hr Za prijevode idite na
hu A fordítások itt érhetők el
it Per le traduzioni consultare
ja 翻訳については、
lt Vertimai patalpinti
lv Tulkojumus skatīt
nl Voor vertalingen zie
no For oversettelser se
pl Aby znaleźć tłumaczenia, sprawdź
pt Consulte as traduções disponíveis em
ro Pentru traduceri, consultați
se För översättningar besök
sk Preklady sú dostupné na stránke
sl Za prevode si oglejte
tr Çeviriler için bkz
zh 翻译见

www.struers.com/Library